

# ROEHR

TOOL SOLUTIONS, INC.

MOULD CONCEPTS 

**DAHANAN**

Tel: +31 (315) 23 11 14  
[www.dahanan.eu](http://www.dahanan.eu)



*Providing Thread & Undercut Release  
Solutions for the Plastics Industry  
Since 1965*



## A Little About Roehr Tool

Roehr Tool, now Roehr Tool Solutions, Inc., has been the industry leader in Collapsible Core technology since George Roehr, a graduate of the Massachusetts Institute of Technology (MIT), developed his first Collapsible Core in 1965.

Founded in 1968 to manufacture the product, Roehr Tool has continued to operate in Massachusetts in the towns of Waltham, Hudson and now Leominster.

Adding product lines through the years such as MiniCores in the mid 1980's, Expandable Cavities in the mid 1990's and the industry changing Dovetail Collapsible Cores in the late 2000's, Roehr Tool continues to be the leader in collapsing and expanding technology for the plastics industry.

Presently owned by industry veterans and longtime Roehr employees David Helenius and Keith Edwards, the company enjoys continued success with additional product development and an ever increasing emphasis on providing engineered solutions to undercut release in molded products.

Not only providing solutions, the company offers opportunities for its customers to gain advantages over their competitors with highly sophisticated, easy to use and precisely manufactured products that provide faster cycle times, less maintenance and simplified operation in the mold.

Roehr Tool Solutions, Inc. is dedicated to total customer support and satisfaction and looks forward to working with your company on all your thread and undercut release challenges.

Please contact us at : 978-562-4488 or [www.roehrtool.com](http://www.roehrtool.com)

Sincerely,

David Helenius  
President/CEO  
[David.Helenius@roehrtool.com](mailto:David.Helenius@roehrtool.com)

Keith Edwards  
Vice President/COO  
[Keith.Edwards@roehrtool.com](mailto:Keith.Edwards@roehrtool.com)



# TABLE OF CONTENTS

<b>Cost Savings Calculator</b>	<b>2</b>
<b>Case Studies</b>	<b>3</b>
<b>Markets Served</b>	<b>4</b>
<b>Benefits</b>	<b>5</b>
<b>DT Core Introduction</b>	<b>6</b>
<b>DT Selection Page</b>	<b>7</b>
<b>DT Construction</b>	<b>8</b>
<b>DT Original Series</b>	<b>9</b>
<b>DT Quick Lock Plate</b>	<b>10</b>
<b>DT Retention Sleeves</b>	<b>11</b>
<b>SUB-10 Introduction</b>	<b>12</b>
<b>SUB-10 Selection Page</b>	<b>13</b>
<b>DT Applications</b>	<b>14</b>
<b>DT Customs</b>	<b>15</b>
<b>RT Introduction</b>	<b>16</b>
<b>RT Selection Page</b>	<b>17</b>
<b>RT Construction</b>	<b>18</b>
<b>MiniCores</b>	<b>19</b>
<b>ExCav Introduction</b>	<b>20</b>
<b>ExCav Mounting Kits</b>	<b>21</b>
<b>ExCav Sequence</b>	<b>22</b>
<b>ExCav Customs</b>	<b>23</b>
<b>Engineering Services</b>	<b>24</b>
<b>Prototyping and Development</b>	<b>25</b>
<b>Companion Products</b>	<b>26 - 27</b>
<b>FAQ's</b>	<b>28</b>
<b>Notes</b>	<b>29</b>

# What your competition does not want you to know...

Molds with Roehr Tool products are less expensive than other methods including unscrewing or side action.

Unscrewing molds need additional components such as timing bars, gears, racks and the ever expensive hydraulic cylinders or servo motors. Side action molds require slides, gibs, locks, angle pins, etc.

None of these are required with the use of Roehr products in your molds as the collapse and eject sequence is generally run off of the machine knock outs.

Roehr products take up a smaller foot print and allow for higher cavitation in a smaller mold and smaller molding machine.

In addition Roehr products provide a 30% on average cycle time reduction!

The case study numbers to the right speak for themselves.

Roehr Tool has an ROI Calculator that you can use to determine just what your savings and ROI would be using our technology. The calculator can be downloaded from our website at: [www.roehrtool.com/resource/dtcalc.htm](http://www.roehrtool.com/resource/dtcalc.htm) or by contacting Roehr directly.

We would welcome the opportunity to "Do The Math" and run the numbers with you.

Region: NA (\$/lb)				
MFG Costs and Capacity				
	Unscrewing Mold	DT Core Gains 1: Cycle Time, Eff, QA	DT Core Gains 2: + Smaller Press	DT Core Gains 3: + Less Cavities
<b>Part Cost:</b>				
Annual Volume	10,000,000	10,000,000	10,000,000	10,000,000
Resin Price (\$/lb)	1	1	1	1
Part Weight (g)	2	2	2	2
<b>Molding:</b>				
Mold Type	Unscrew	DT Core	DT Core	DT Core
Cycle Time (s)	12	7	7	7
Cavitation	16	16	16	8
Productivity	80%	90%	90%	90%
Threaded Core Cost	\$750	\$4,000	\$4,000	\$4,000
Press Rate (\$/hr)	50	50	40	40
Maintenance Hrs/year	84	42	42	42
Quality, % defect	1.0%	0.5%	0.5%	0.5%
<b>Assumptions:</b>				
Production Hrs per Week	40	40	40	40
Production Weeks per Year	45	45	45	45
Toolroom Rate	\$50	\$50	\$50	\$50
Overhead (% upcharge)	25%	25%	25%	25%
Molder's Profit Margin (%)	20%	20%	20%	20%
<b>Result:</b>				
Part Cost (\$/1000)	\$26	\$17	\$15	\$23
Capital Cost Est (\$)	\$138,600	\$168,000	\$168,000	\$84,000
Capacity	6,912,000	13,330,286	13,330,286	6,665,143
Maint & QA Cost	\$6,814	\$2,937	\$2,835	\$3,241
<b>Savings:</b>				
Annual Part Savings (\$)		\$97,917	\$118,272	\$36,849
ROI (1 Yr Savings)		\$68,517	\$88,872	\$91,449
ROI 5 Yr (\$)		\$460,183	\$561,962	\$238,844
Capacity Gain		\$6,418,286	\$6,418,286	-\$246,857

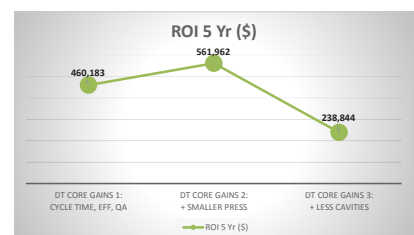
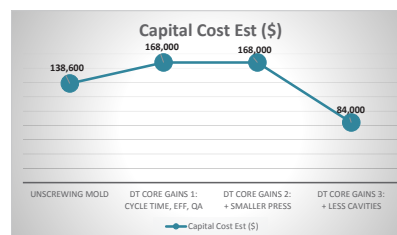
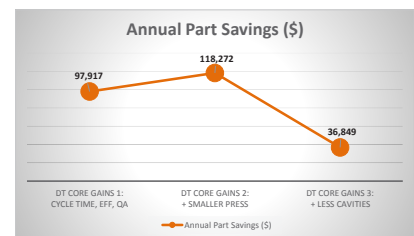
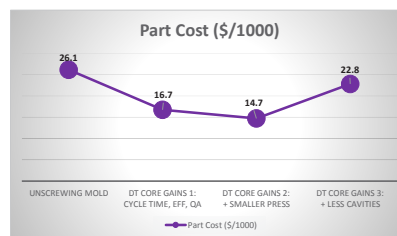

## Case Study: Mold-Rite Plastics

Mold-Rite Plastics, Inc. was evaluating whether to refurbish or replace an old 48-cavity unscrewing mold that was manufacturing a viable and in-demand 24mm cap.

After learning about DT Collapsible Cores, Mold-Rite was able to do the math and see the cost advantages of replacing the 20-year-old mold with one utilizing new technology that would run faster and simpler, with less maintenance and downtime. The results and cost savings were dramatic:

Original Mold	New DT Core Mold
48 cavity	24 cavity
24-second cycle	10-second cycle
7,200 pcs/hr	8,640 pcs/hr
300 ton machine	200 ton machine

Roehr President Dave Helenius said, "Mold-Rite is able to run the mold faster and in a smaller machine, decreasing the cost per thousand parts by 30%. Additionally,

the cost of yearly maintenance and quality decreased 46% with the DT Core mold. This is significant."

"If we plug Mold-Rite's data into our online Cost Savings Calculator, capital cost savings are notable," Helenius adds. **"By converting to a simpler DT Core mold, Mold-Rite reduced their overall mold build costs by 60%."**

"The technical support was excellent" commented the senior design engineer and toolroom manager at Mold-Rite. "We learned proper handling, disassembly and assembly of the cores, as well as installation of the cores into the mold base. Everything went very smoothly and the overall results speak for themselves."



*With DT Cores, no hydraulics or external core pull mechanisms are required.*



## Case Study: Pilgrim Innovative Plastics, LLC

Pilgrim Innovative Plastics, LLC has worked with Roehr Tool over the last 10 to 12 years on several injection molds that would typically have required unscrewing actions. "We were able to design molds which ran cycles about 20% faster due to the fact that the thread undercuts cleared themselves with a single knockout stroke rather than the time to rotate a core to demold and reset in position, as well as the timing necessary to eject after unscrewing." says Pilgrims President, Joel Nickerson. "Set ups are also simpler as there are no hydraulics or electric motors required." added Joel.

"Recently, Roehr replaced two cores for a mold with 2" pipe threads, which were getting a little tired after producing 2 million parts over the last 10 years, and the threads look great. The life of the first set of cores exceeded our expectations with no maintenance except simple lubrication."

"We were also fortunate to have a design challenge remedied with one of the first of their Dovetail Collapsible Cores. The part had submerged cams in the moving half of the mold and we needed threads on the stationary "A" half. The mechanical Dovetail design allowed us to build a very robust mold which ran exceptionally well. We couldn't have built it reasonably any other way. Again Roehr Tool came through with a unique solution."

"Roehr's design assistance has been quite beneficial with our thread and undercut challenges and they have never let us down. I recommend Roehr Tool collapsible cores for any application they feel they can satisfy." concluded Joel.



# Markets Served



Medical

Irrigation



Caps and Closures  
(Packaging)

Plumbing



Industrial

Automotive



# Benefits



**Faster Cycle Times**

**Increased Profits**

**Less Maintenance**

**No Hydraulics**

**Smaller Molds**

**Smaller Presses**

**Lower Cost of Ownership**

**Simplified Operation**

**Quicker ROI**

**Eliminates Secondary  
Operations**

**Balanced Layout**

**Energy Savings**

**Non-Round Shapes**



# COLLAPSIBLE CORES

## DOVETAIL "DT" SERIES

### Increased Profits

DT Collapsible Cores offer a unique opportunity to revisit older tooling designs and rebuild or refurbish the molds for maximum production efficiency and profitability. Many molders have realized the cost-saving and profit-boosting benefits of using DT Cores.

DT Cores allow for:

- Simplified, smaller molds
- Faster cycle times
- Improved part quality
- Reduced mold maintenance
- Ability to rebuild existing tools and breathe new life into old unscrewing molds.
- Conversion to DT Cores through replacement mold or back half rebuild

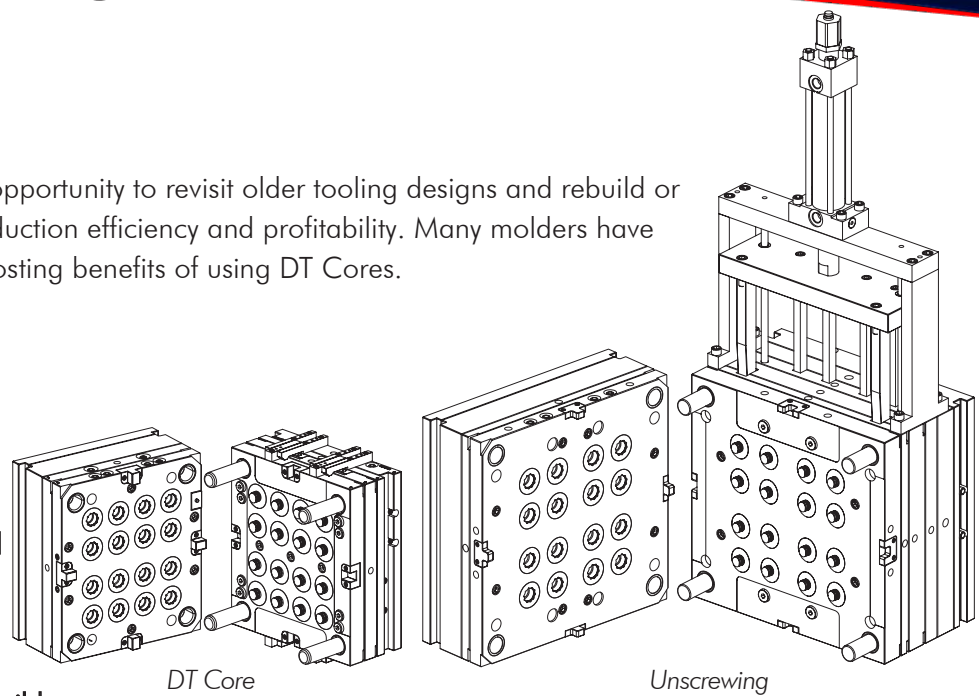

**Do the Math...** Let Roehr Tool help you calculate the ROI for your next project at [www.roehrtool.com/resource/dtcalc.htm](http://www.roehrtool.com/resource/dtcalc.htm), or we would be happy to run the numbers on savings and calculate the ROI for you.

### Simplified Mold Design

The DT Collapsible Core is a positive, mechanically actuated collapsible core that eliminates complex gear and rack approaches, resulting in a simpler mold and a faster cycle time.

The maintenance advantage is dramatic due to a patented quick-lock feature that allows removal and servicing of the core unit while the mold is still in the press.

The DT Core's compact design allows for shorter stack height, tighter cavity spacing, and also creates opportunities for use in slides or on the stationary side of the mold.

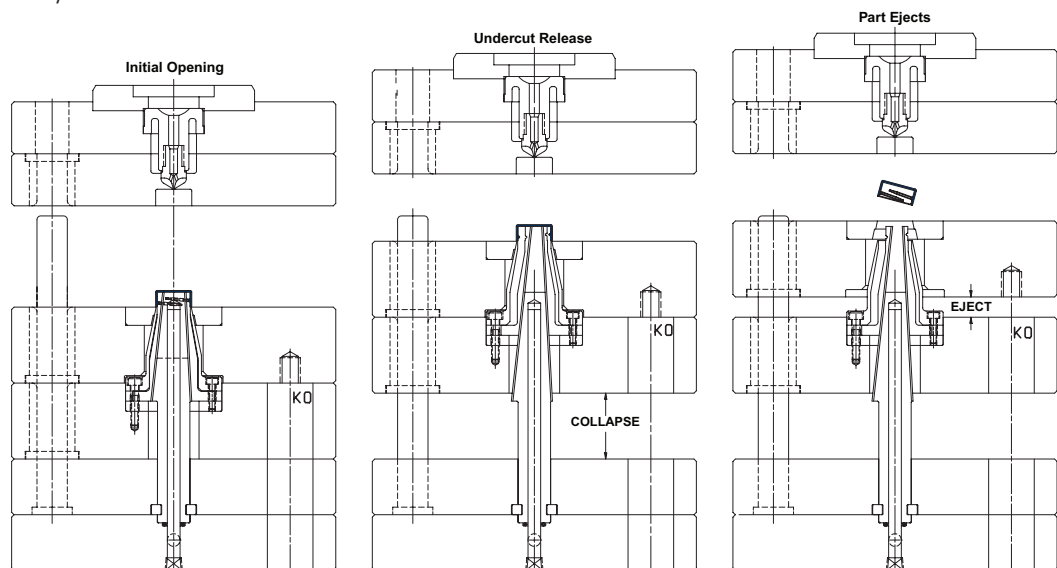

*DT Cores use a simple single stage collapse/eject sequence typically run by the machine KO.*

# COLLAPSIBLE CORES

## DOVETAIL "DT" SERIES

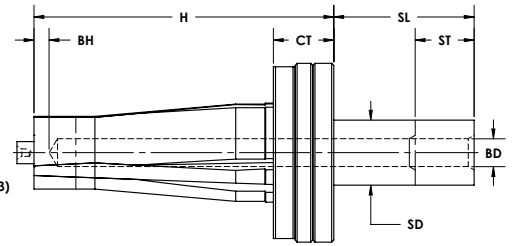
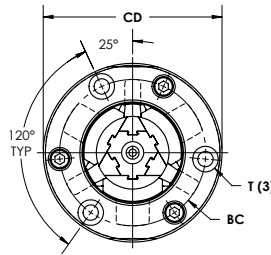
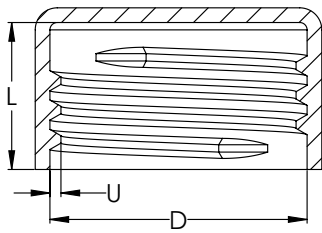

CATALOG NUMBER	D Maximum Outer Diameter	U Max Undercut	L Maximum Molding Length	ST Maximum Collapse Stroke	H Core Length	SD Shaft Diameter	BD Cooling Hole Diameter	BH Distance to Cooling Hole	SL Shaft Length	CD Carrier Diameter	CT Carrier Assembly Thickness	BC Mounting Screw Bolt Circle	T Mounting Screws (SHCS)
DT1010	10.00-10.99mm .394-.433in	.36mm .014in	7.5mm .295in	43.5mm 1.713in	87mm 3.425in	10.5mm .413in	3mm .1in	5mm .2in	58mm 2.283in	50mm 1.969in	21mm .827in	37mm 1.457in	M5 x 25
DT1111	11.00-11.99mm .433-.472in	.41mm .016in	8mm .315in	44.5mm 1.752in									
DT1212	12.00-12.99mm .472-.511in	.46mm .018in	8.5mm .335in	45.5mm 1.791in	87mm 3.425in	12mm .472in	4mm .2in	5mm .2in	59mm 2.323in	52mm 2.047in	21mm .827in	38mm 1.496in	M6 x 35
DT1313	13.00-13.99mm .512-.551in	.51mm .020in	9mm .354in	46.5mm 1.831in									
DT1414	14.00-14.99mm .551-.590in	.56mm .022in	9.5mm .374in	47mm 1.850in	87mm 3.425in	14mm .551in	5mm .2in	5mm .2in	60mm 2.362in	54mm 2.126in	21mm .827in	41mm 1.614in	M5x25
DT1515	15.00-15.99mm .591-.630in	.61mm .024in	10mm .394in	47.5mm 1.870in									
DT1616	16.00-16.99mm .630-.669in	.66mm .026in	10.5mm .413in	48mm 1.890in	87mm 3.425in	15.5mm .610in	6mm .2in	5mm .2in	62mm 2.441in	56mm 2.205in	21mm .827in	43mm 1.693in	M5x25
DT1717	17.00-17.99mm .669-.708in	.71mm .028in	11mm .433in	48.5mm 1.909in									
DT1819	18.00-19.99mm .709-.787in	.82mm .032in	12mm .472in	50mm 1.969in	99mm 3.898in	18mm .709in	8mm .3in	6mm .2in	61mm 2.402in	63mm 2.480in	24mm .945in	49mm 1.929in	M6x30
DT2021	20.00-21.99mm .787-.866in	.92mm .036in	12.5mm .492in	55mm 2.165in									
DT2224	22.00-24.99mm .866-.984in	1.04mm .041in	13mm .512in	59mm 2.323in	109mm 4.291in	22mm .866in	10mm .4in	6mm .2in	64mm 2.520in	69mm 2.717in	24mm .945in	55mm 2.165in	M6x30
DT2527	25.00-27.99mm .984-1.102in	1.20mm .047in	15mm .591in	66.5mm 2.618in									
DT2830	28.00-30.99mm 1.102-1.220in	1.36mm .053in	18mm .709in	71mm 2.795in	129mm 5.079in	28mm 1.102in	12mm .5in	6mm .2in	60mm 2.362in	77mm 3.031in	26mm 1.024in	63mm 2.480in	M6x30
DT3133	31.00-33.99mm 1.220-1.338in	1.50mm .059in	21mm .827in	78mm 3.071in									
DT3436	34.00-36.99mm 1.339-1.456in	1.73mm .068in	22mm .866in	79mm 3.110in	139mm 5.472in	34mm 1.339in	14mm .6in	6mm .2in	64mm 2.520in	93mm 3.661in	27mm 1.063in	75mm 2.953in	M8x30
DT3739	37.00-39.99mm 1.457-1.574in	1.88mm .074in	24mm .945in	85mm 3.346in									
DT4042	40.00-42.99mm 1.575-1.693in	2.06mm .081in	25mm .984in	86mm 3.386in	151mm 5.945in	39mm 1.535in	17mm .7in	6mm .2in	65mm 2.559in	101mm 3.976in	32mm 1.260in	83mm 3.268in	M8x35
DT4345	43.00-45.99mm 1.693-1.811in	2.24mm .088in	27mm 1.063in	93mm 3.661in									
DT4648	46.00-48.99mm 1.811-1.929in	2.42mm .095in	28mm 1.102in	94mm 3.701in	161mm 6.339in	42mm 1.654in	20mm .8in	6mm .2in	69mm 2.717in	110mm 4.331in	32mm 1.260in	90mm 3.543in	M8x35
DT4951	49.00-51.99mm 1.929-2.047in	2.57mm .101in	31mm 1.220in	99mm 3.898in									
DT5254	52.00-54.99mm 2.047-2.165in	2.77mm .109in	32mm 1.260in	100mm 3.937in	183mm 7.205in	50mm 1.969in	22mm .9in	6mm .2in	85mm 3.346in	130mm 5.118in	39mm 1.535in	107mm 4.213in	M10x45
DT5557	55.00-57.99mm 2.165-2.283in	2.95mm .116in	34mm 1.339in	106mm 4.173in									
DT5860	58.00-60.99mm 2.283-2.401in	3.10mm .122in	36mm 1.417in	111mm 4.370in									

FOR SIZES LARGER THAN 60MM, CONTACT ROEHR DIRECTLY

## COLLAPSIBLE CORES DT SERIES CONSTRUCTION

### Collapsing Segments

**M** A-2 **H** 54-57 HRC

- Designed to mechanically collapse when the center pin is withdrawn.
- The fit between the segments is controlled to permit flash-free molding.

### Center Pin

**M** D-2 **H** 60-62 HRC

- Serves to expand the segments of the core to their molding position
- The pin may be flush to the core face.

### Carrier Assembly

**M** D-2 **H** 60-62 HRC

- Mounts DT Core assembly to the mold carrier plate.
- Provides guided and anti-rotational segment movement.

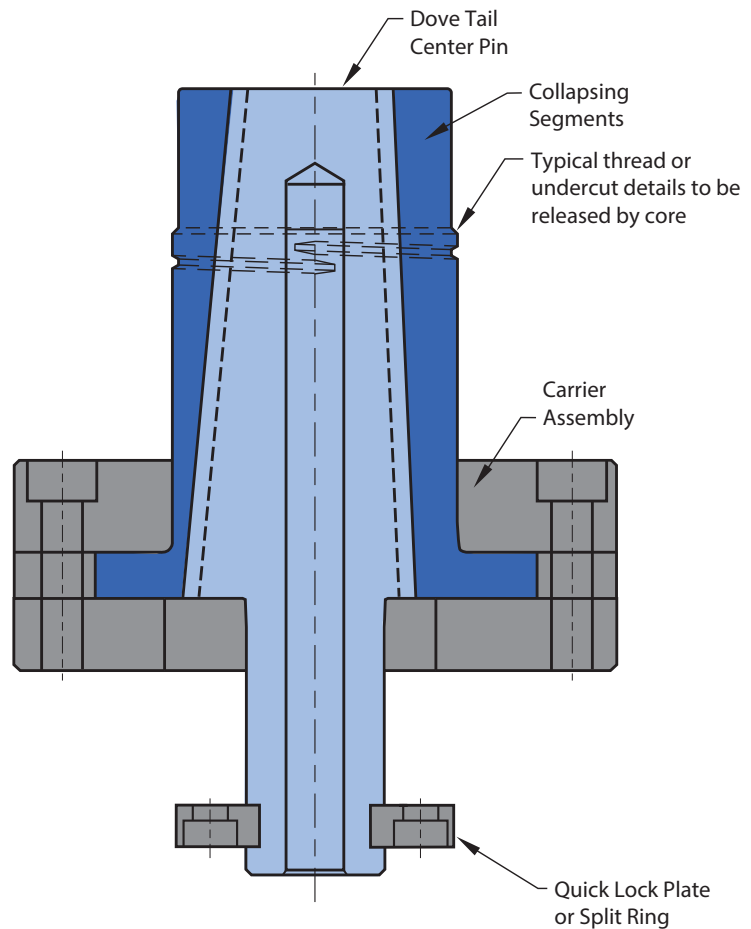

## COLLAPSIBLE CORES SETRAL GREASE INFORMATION

Setral is a full synthetic, solid free non-migrating grease for long term lubrication that is used to coat the sliding surfaces between our segments and center pin. Roehr recommends this grease for all DT core applications. MSDS and technical data sheets are available from Roehr Tool.

Ordering Information:

Catalog Number: DTG-100

Description: Setral INT/300 Grease : 100g Tube



# COLLAPSIBLE CORES

## DT ORIGINAL SERIES

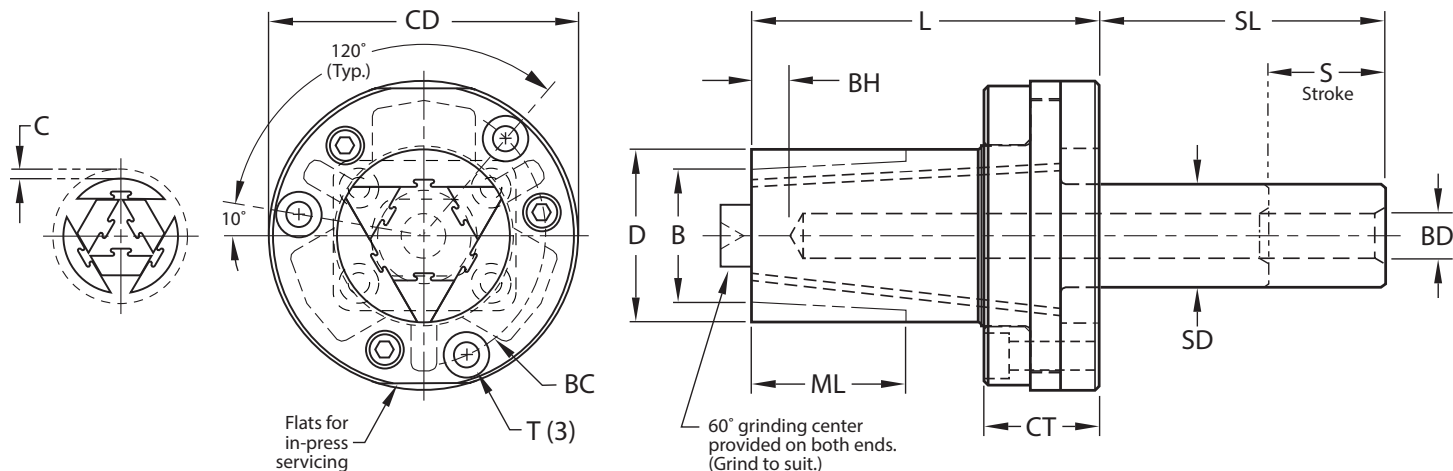

CATALOG NUMBER	D Maximum Outer Diameter	B Minimum Inner Diameter +3°/Side	ML Maximum Molding Length	C Maximum Collapse	CD Carrier Diameter +0.00 -0.05	CT Carrier Assembly Thickness ± 0.05	L Core Length +0.1 -0.0	SL Shaft Length	SD Shaft Diameter +0.00 -0.02	BD Cooling Hole Diameter	BH Distance to Cooling Hole	BC Mounting Screw Bolt Circle	T Mounting Screws	S Maximum Collapse Stroke
DT18	21mm .827in	17mm .669in	22mm .866in	1.1mm .043in	53mm 2.087in	21mm .827in	60mm 2.362in	60mm 2.362in	16mm .630in	6mm .236in	6mm .236in	40mm 1.575in	M5 x 25	34mm 1.339in
DT28	33mm 1.299in	25mm .984in	28mm 1.102in	1.6mm .063in	60mm 2.362in	22mm .866in	67mm 2.638in	60mm 2.362in	20mm .787in	8mm .315in	8mm .315in	47mm 1.850in	M5 x 25	38mm 1.496in
DT38	42mm 1.654in	33mm 1.299in	43mm 1.693in	2.1mm .083in	76mm 2.992in	28mm 1.102in	85mm 3.346in	60mm 2.362in	25mm .984in	10mm .394in	10mm .394in	60mm 2.362in	M6 x 35	54mm 2.126in
DT48	54mm 2.126in	42mm 1.654in	50mm 1.969in	2.4mm .094in	98mm 3.858in	37mm 1.457in	104mm 4.094in	70mm 2.756in	30mm 1.181in	12mm .472in	12mm .472in	78mm 3.071in	M8 x 40	62mm 2.441in

NOTE: Submit part geometry to [information@roehrtool.com](mailto:information@roehrtool.com) for quotes and application review.

## COLLAPSIBLE CORES

### DT SERIES GRINDING FIXTURES

Grinding Fixtures for DT Collapsible Cores securely hold the core segments in place against the center pin when grinding, high speed machining or EDM'ing details.

M A-2 H 54-57 HRC



Although normally Roehr would provide cores with finished molding details, grinding fixtures allow customers to machine their own details.

CATALOG NUMBER	CORE SIZE
DTGF1011	DT1011
DTGF1213	DT1213
DTGF1415	DT1415
DTGF1617	DT1617
DTGF1821	DT1821
DTGF2227	DT2227
DTGF2833	DT2833
DTGF3439	DT3439
DTGF4045	DT4045
DTGF4651	DT4651
DTGF5260	DT5260
DTGF18	DT18
DTGF28	DT28
DTGF38	DT38
DTGF48	DT48

# COLLAPSIBLE CORES

## DT SERIES QUICK LOCK PLATE (OPTIONAL)

### Quick Lock Feature

Plate Material: A-2, 54-57 HRC

Utilizing Roehr's exclusive Quick Lock mounting configuration, the DT Core can be removed and serviced while the mold remains in the press. This feature allows for a higher cavitation percentage and lower maintenance costs than other tool design approaches.

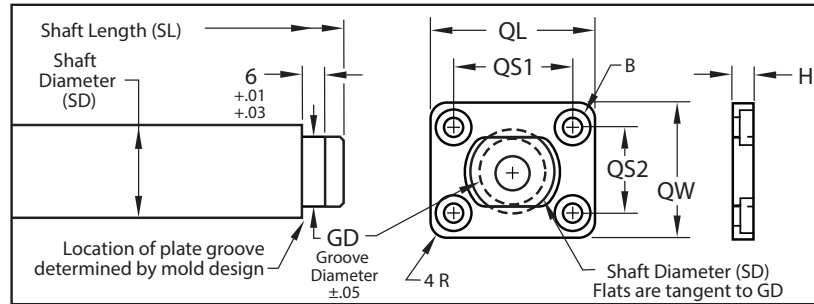

DOVE TAIL CATALOG NUMBER	GD	QL +0.00 -0.05	QW +0.00 -0.05	QS1	QS2	H	B MOUNTING SCREWS
DT1011	7.43mm .93in	26.01mm 1.024in	18.01mm .709in	17.50mm .689in	9.50mm .374in	4mm .1575in	M3 LHCS
DT1213	9.02mm .355in	27.99mm 1.102in	18.01mm .709in	19.51mm .768in	9.50mm .374in	4mm .1575in	M3 LHCS
DT1415	9.81mm .386in	30mm 1.181in	19.99mm .787in	21.49mm .846in	11.51mm .453in	5mm .1969in	M3 SHCS
DT1617	10.60mm .417in	32mm 1.260in	22mm .866in	23.50mm .925in	13.49mm .531in	5mm .1969in	M3 SHCS
DT1821	12.99mm .511in	35mm 1.378in	24.99mm .984in	24.99mm .984in	15.01mm .591in	6mm .2362in	M4 SHCS
DT2227	16.16mm .636in	38mm 1.496in	27.99mm 1.102in	27.99mm 1.102in	18.01mm .709in	6mm .2362in	M4 SHCS
DT2833	21.72mm .855in	43.99mm 1.732in	32mm 1.260in	34.01mm 1.339in	22mm .866in	6mm .2362in	M4 SHCS
DT3439	25.69mm 1.011in	51.99mm 2.047in	40.01mm 1.575in	40.01mm 1.575in	27.99mm 1.102in	8mm .3150in	M5 SHCS
DT4045	30.45mm 1.199in	56.01mm 2.205in	43.99mm 1.732in	43.99mm 1.732in	32mm 1.260in	8mm .3150in	M5 SHCS
DT4651	34.42mm 1.355in	57.99mm 2.283in	46mm 1.811in	46mm 1.811in	34.01mm 1.339in	8mm .3150in	M5 SHCS
DT5260	39.18mm 1.543in	65.99mm 2.598in	54mm 2.126in	53.01mm 2.087in	41mm 1.614in	10mm .3937in	M6 SHCS
DT18	12mm .472in	35mm 1.378in	22mm .866in	25mm .984in	12mm .472in	6mm .236in	M4 SHCS
DT28	15mm .591in	38mm 1.496in	25mm .984in	28mm 1.102in	15mm .591in	6mm .236in	M4 SHCS
DT38	19mm .748in	41mm 1.614in	31mm 1.220in	30mm 1.181in	20mm .787in	6mm .236in	M4 SHCS
DT48	23mm .906in	44mm 1.732in	35mm 1.378in	34mm 1.339in	25mm .984in	6mm .236in	M4 SHCS

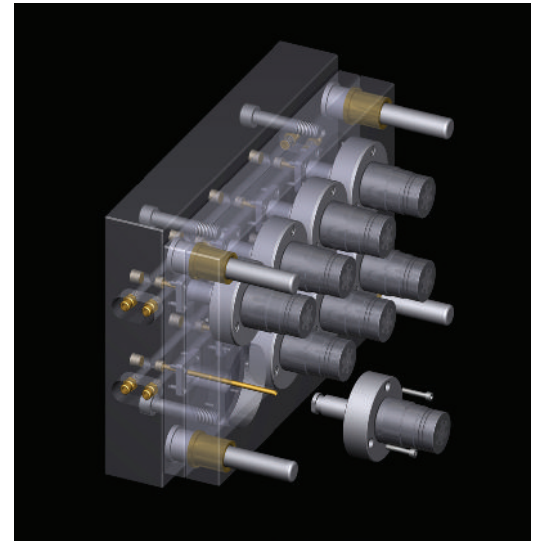

US PATENT NUMBER: 8,033,810

Align and push end of Center Pin through Quick Lock Plate.

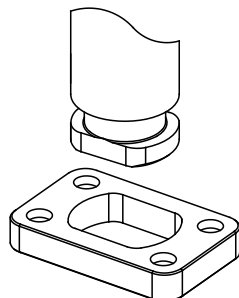

Rotate Center Pin clockwise 90° to lock into place.

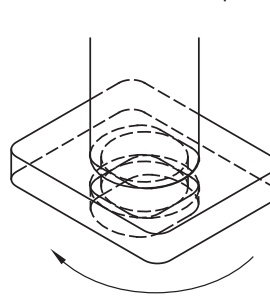

Bottom view of Center Pin and Quick Lock Plate in locked position.

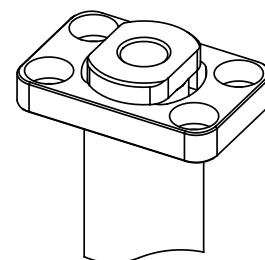

# COLLAPSIBLE CORES

## DT SERIES SPLIT RING

M A-2 H 54-57 HRC

Utilizing Roehr's split ring allows for a simpler attachment method.

CATALOG NUMBER	A Outer Diameter	B Inner Diameter	C THICKNESS
DTSR1011	16mm .63in	7.95mm .313in	3.99mm .157in
DTSR1213	17.53mm .69in	9.53mm .375in	3.99mm .157in
DTSR1415	20.32mm .80in	10.31mm .406in	5mm .197in
DTSR1617	21.08mm .83in	11.13mm .438in	5mm .197in
DTSR1821	25.40mm 1.00in	13.49mm .531in	5.99mm .236in
DTSR2227	28.70mm 1.13in	16.66mm .656in	5.99mm .236in
DTSR2833	34.29mm 1.35in	22.23mm .875in	5.99mm .236in
DTSR3439	42.16mm 1.66in	26.19mm 1.031in	8mm .315in
DTSR4045	46.99mm 1.85in	30.96mm 1.219in	8mm .315in
DTSR4651	50.80mm 2.00in	34.93mm 1.375in	8mm .315in
DTSR5260	59.69mm 2.35in	39.70mm 1.563in	9.98mm .393in
DTSR18	24.89mm .98in	12.70mm .500in	6.35mm .250in
DTSR28	27.94mm 1.10in	15.88mm .625in	6.35mm .250in
DTSR38	34.80mm 1.37in	20.62mm .812in	6.35mm .250in
DTSR48	37.59mm 1.48in	25.40mm 1.000in	6.35mm .250in

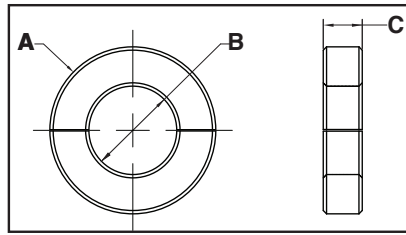

Assemble Core into Mold.  
Then collapse core to install  
split ring

Push Center pin forward to  
molding position and install  
back plate

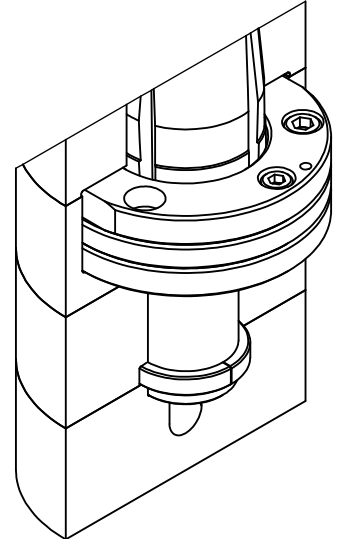
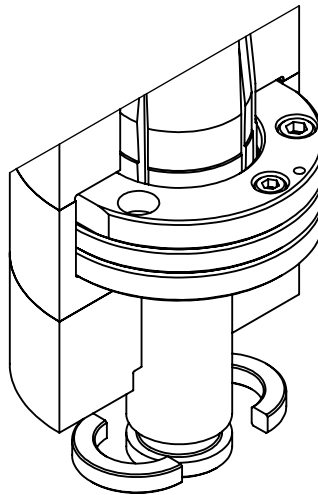

## COLLAPSIBLE CORES DT SERIES RETENTION SLEEVE (OPTIONAL)

M D-2 H 60-62 HRC

Retention Sleeves for DoveTail Collapsible Cores assure the position of the molded part during core collapse and part ejection.

E-mail [information@roehrtool.com](mailto:information@roehrtool.com) for more information.

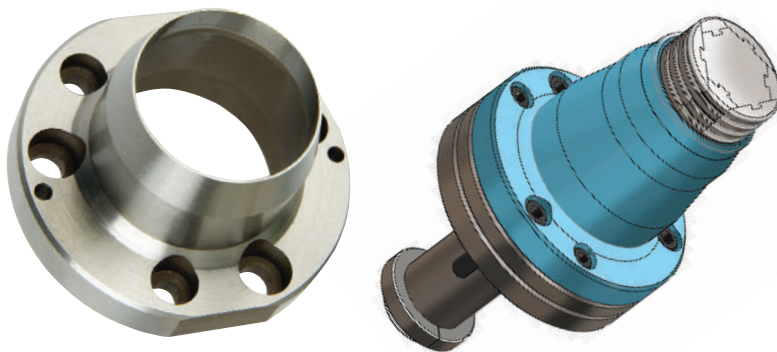

US PATENT NUMBER: 9,011,138

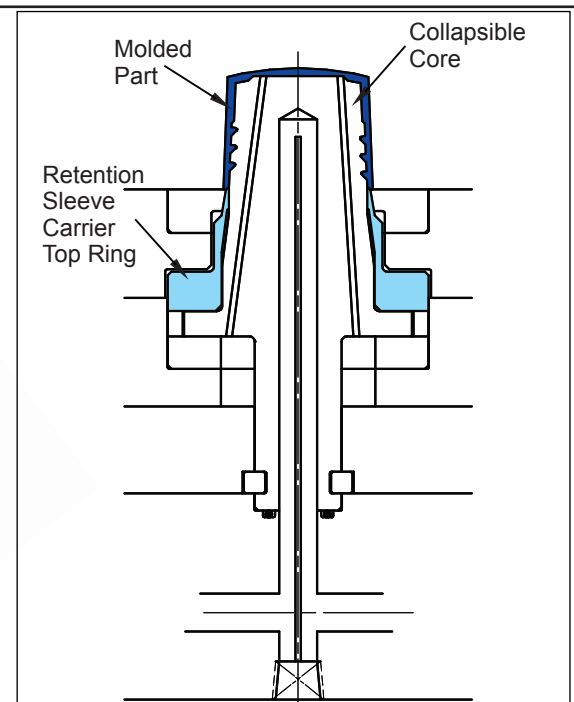

## COLLAPSIBLE CORES

### SUB-10 DT CORE SERIES

The Sub-10 DT Cores make it possible to release very small threads and undercuts in molded caps, connectors and small medical parts.

- Allows molding of parts with 7-10mm ID.
- Simpler alternative to unscrewing molds.
- Reduces cycle time and maintenance requirements.

#### Application Guidelines:

- Maximum undercut depth is determined by final molding diameter from application review.
- Collapse stroke is determined by undercut depth from application review.
- Cores are supplied complete with machined molding details.



# COLLAPSIBLE CORES

## SUB-10 DT CORE SERIES

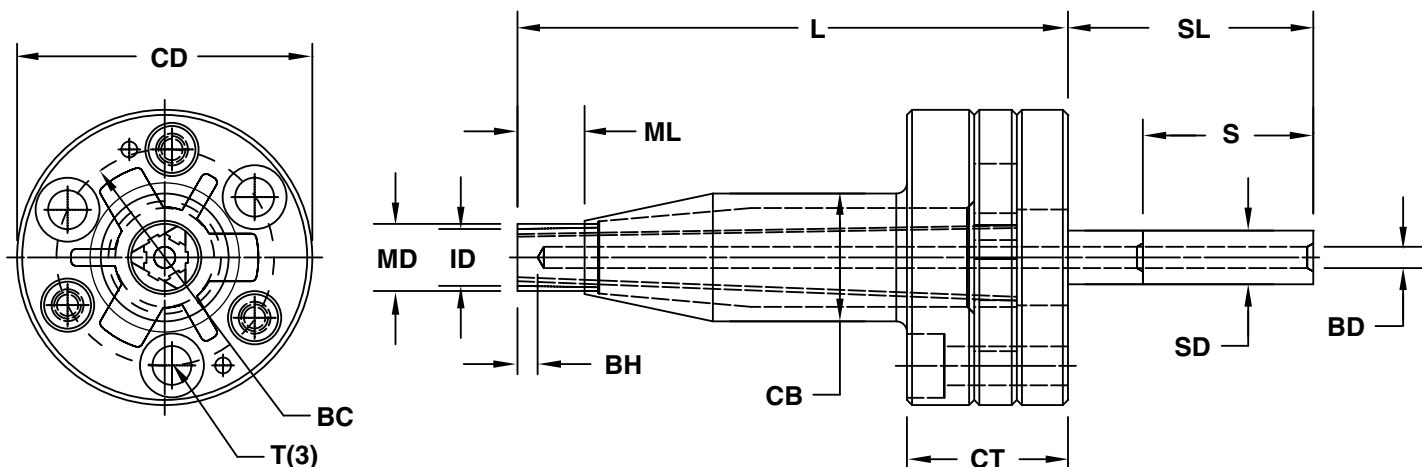

CATALOG NUMBER	MD Maximum Molding Diameter	ID Minimum Molding Diameter	ML Maximum Molding Length	UC Maximum Undercut	CD Carrier Assembly Diameter	CB Carrier Assembly Body	CT Carrier Assembly Thickness	L Length	SL Shaft Length	SD Shaft Diameter	S Maximum Collapse Stroke	BD Cooling Hole Diameter	BH Cooling Hole Height	BC Mounting Bolt Circle	T Mounting Bolt (3)
SUB-10	10mm .394in	7mm .276in	10mm .394in	.38mm .015in	44mm 1.732in	19mm .748in	24mm .945in	82mm 3.228in	36mm 1.417in	8mm .315in	50mm 1.969in	3mm .118in	3mm .118in	32mm 1.260in	M5x25

NOTE: Submit part geometry to [information@roehrtool.com](mailto:information@roehrtool.com) for quotes and application review.

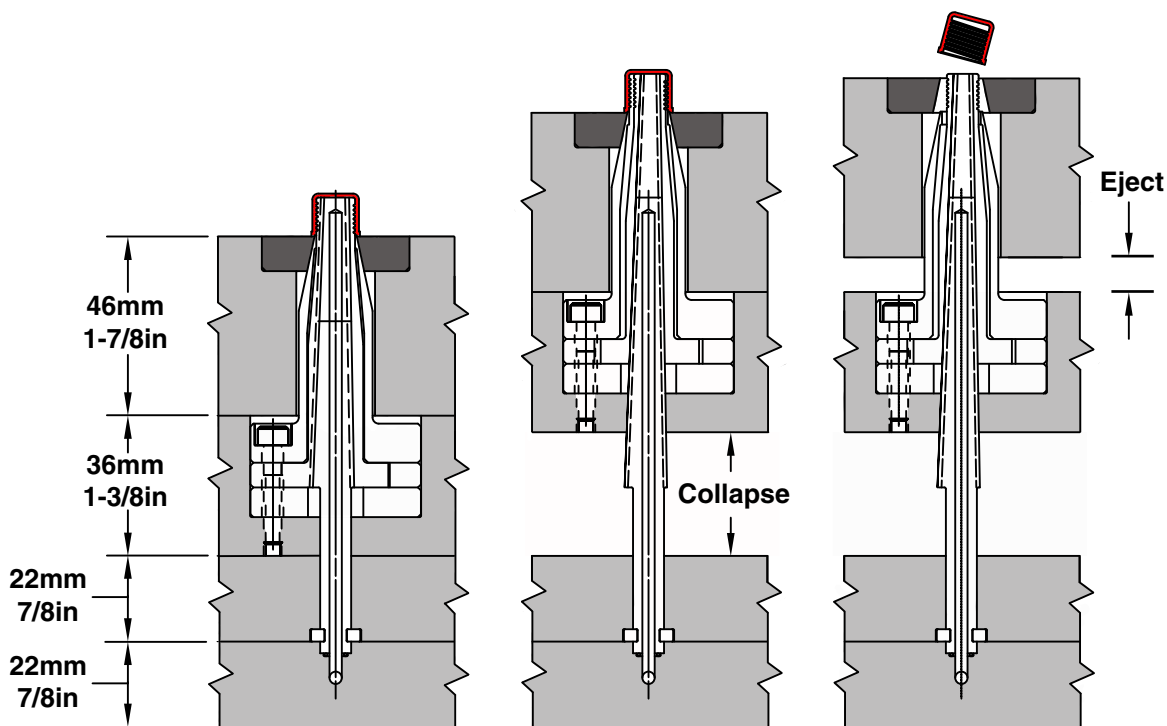

# COLLAPSIBLE CORES

## DT SERIES APPLICATIONS

### Side Action

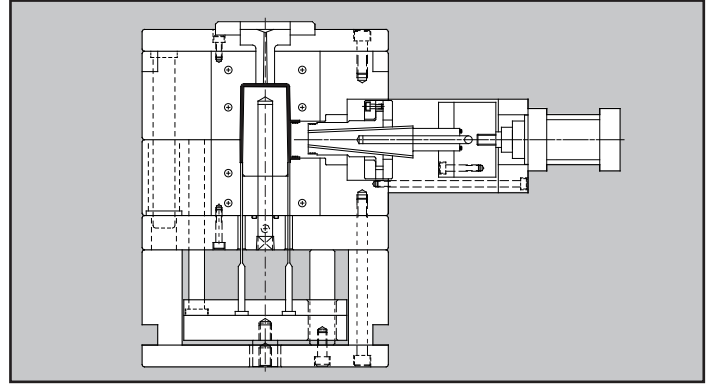
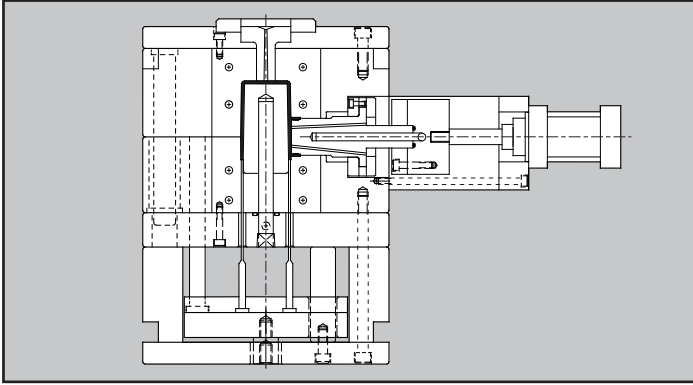

### Cavity Side

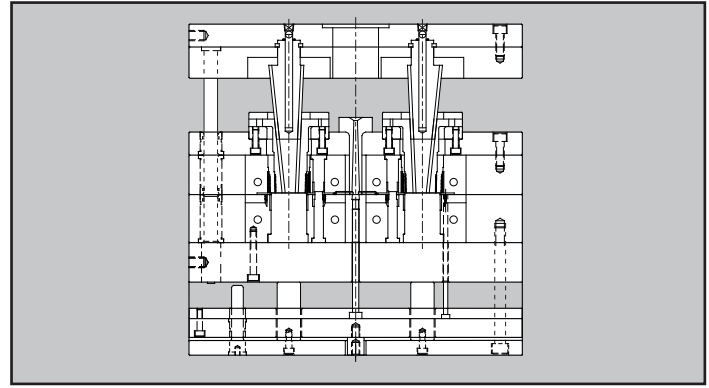
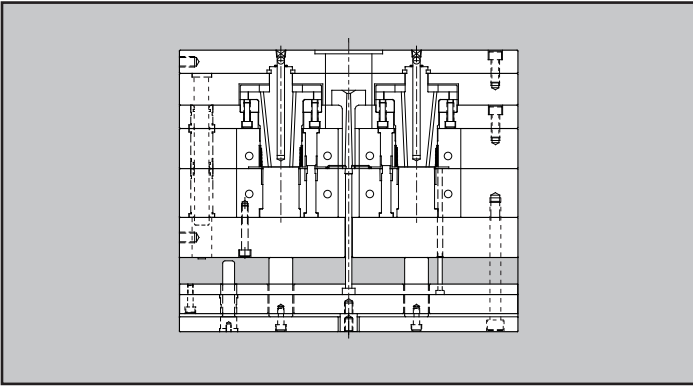

### Boss Detail

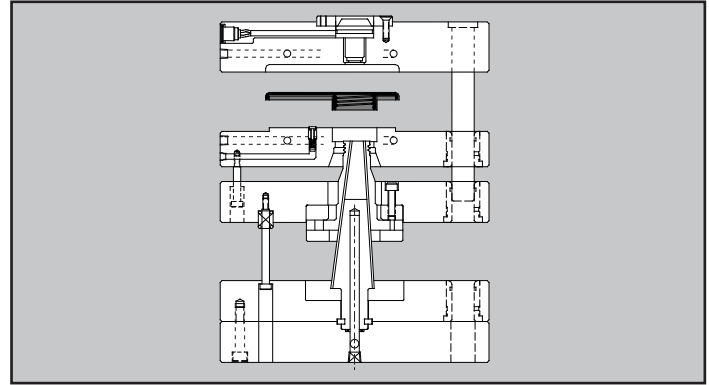
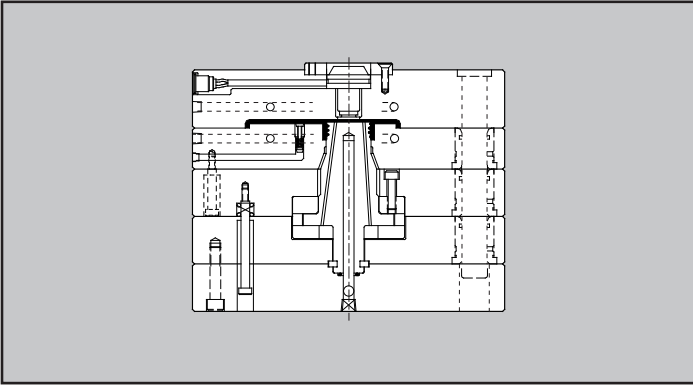

### Seal Ring (Pancake Pin)

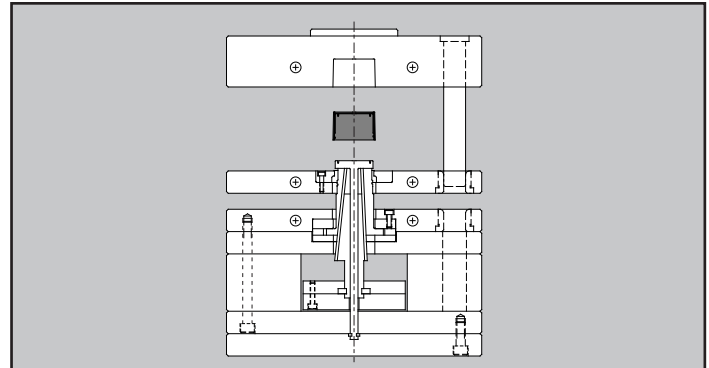
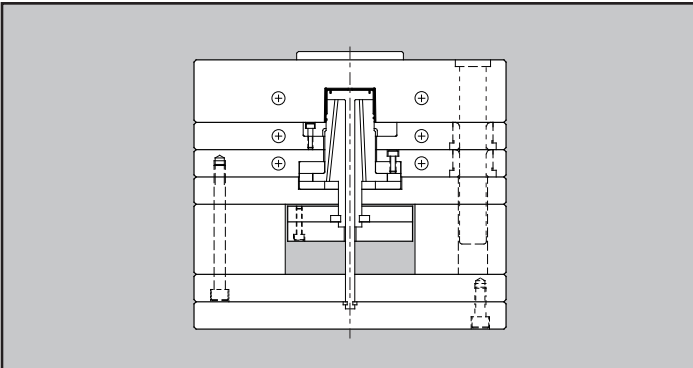

# COLLAPSIBLE CORES DT SERIES CUSTOM APPLICATIONS

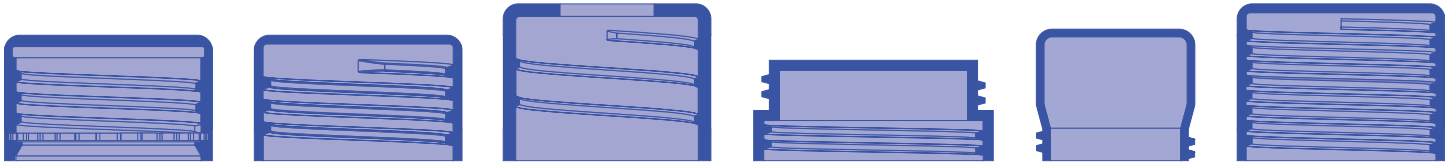
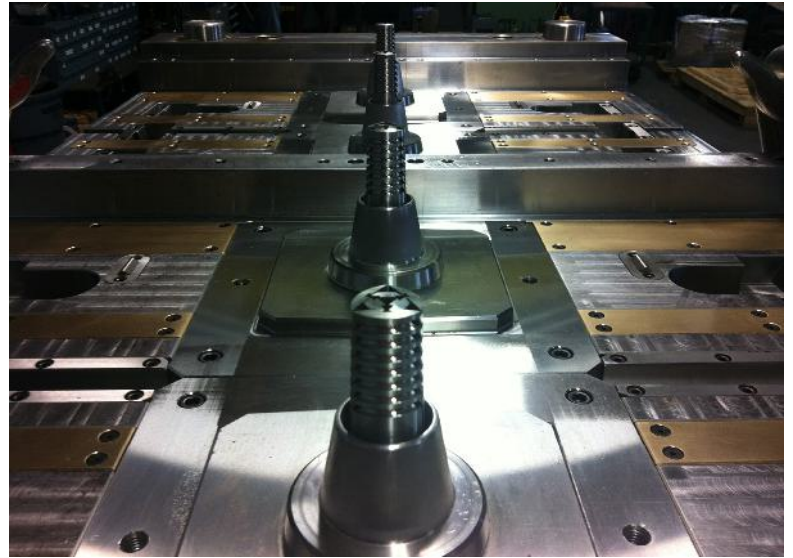

TE Cap

CT Cap

Threaded Collar

Prescription

Dosing

Long Thread Run

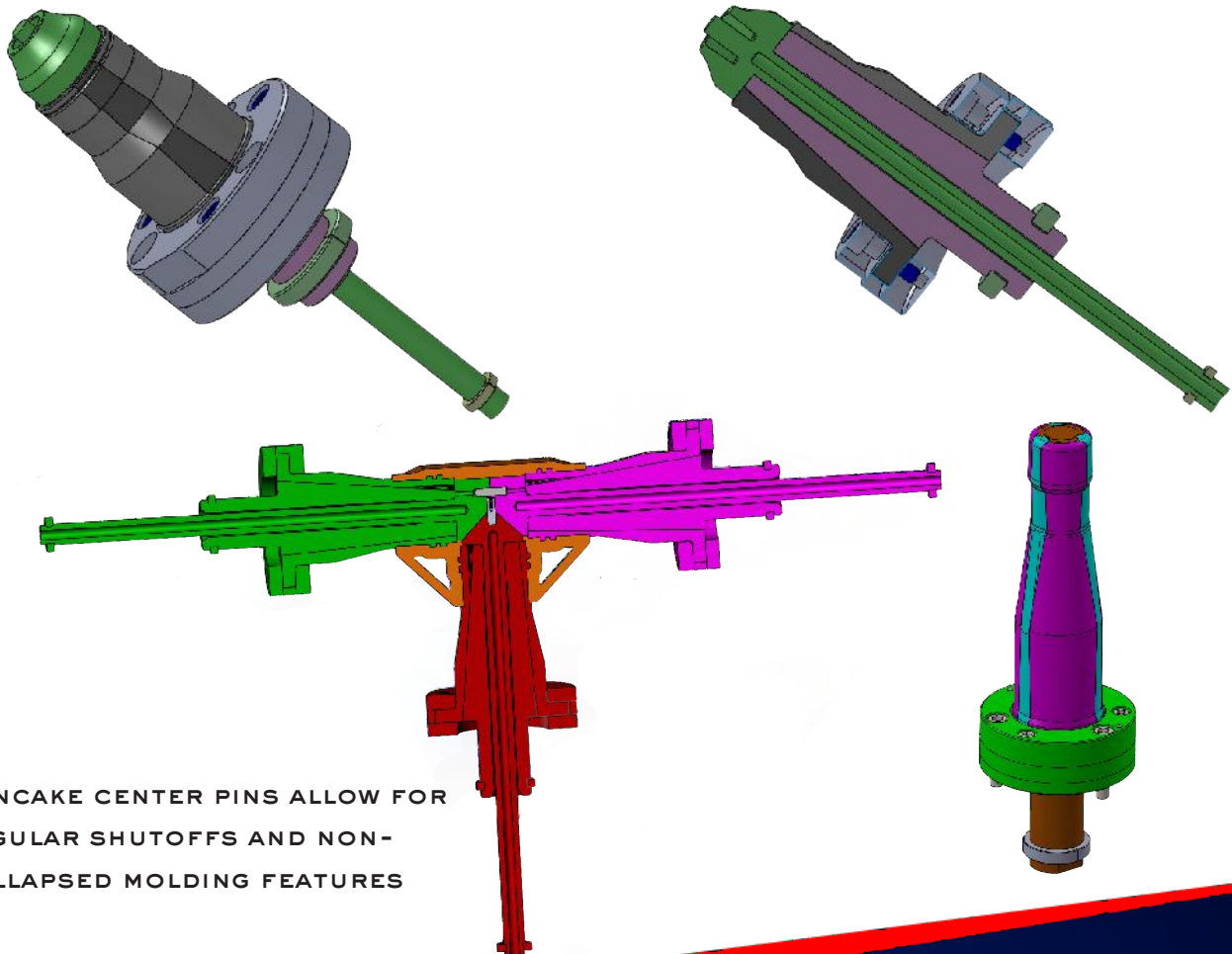

PANCAKE CENTER PINS ALLOW FOR ANGULAR SHUTOFFS AND NON-COLLAPSED MOLDING FEATURES

# COLLAPSIBLE CORES

## RT SERIES

The RT Series Collapsible Cores (RT) are available in sizes to fit most inside detail applications. Whether molding threads or complex details, these cores can simplify design and production. Collapsible Cores allow for smaller molds to run faster cycles with less moving parts.

Standard diameters range from 13mm to 105mm.

Made from premium tool steels and heat treated using proprietary heat treating methods.



1

### Mold Closed

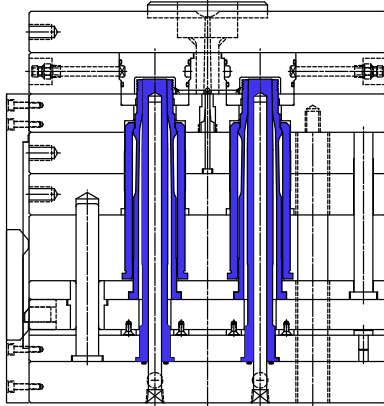

2

### Mold Open

Ejector plate and stripper plate move forward, and the Collapsible Core is collapsed.

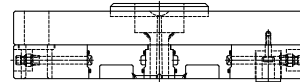

3

### Part Ejected

Machine pushes the stripper plate forward, ejecting the molded part.

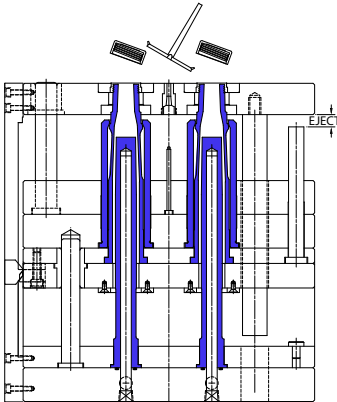
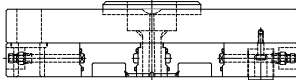

Roehr Tool can provide Collapsible Cores with details machined complete. Contact an engineer at [information@roehrtool.com](mailto:information@roehrtool.com) for an application review and quotation.

# COLLAPSIBLE CORES

## RT SERIES

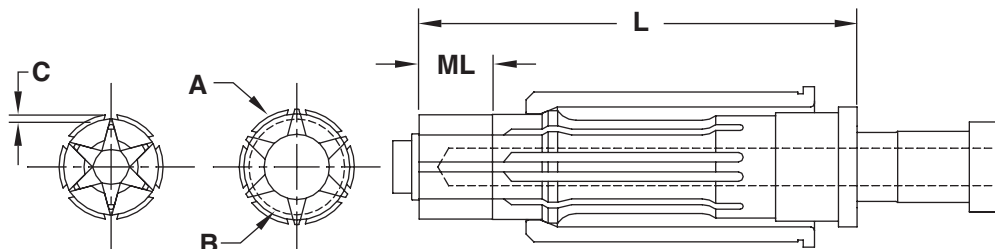

CATALOG NUMBER	A Maximum Outer Diameter		B Minimum Inner Diameter		Center Pin Diameter (At top of Collapsible Core)		ML Max. Molded Length (Including Mold Shut-Off)		C Collapse per Side at Top of Core** (Range Shown)				L Length of Collapsible Core	
	Inch	mm	Inch	mm	Inch	mm	Inch	mm	Inch	mm	Inch	mm	Inch	mm
CC-125-PC	.720	18.29	.620	15.75	.485	12.32	.800	20.32	.027	.69	.032	.81	5.605	142.37
CC-150-PC	.850	21.59	.700	17.78	.580	14.73	1.000	25.40	.037	.94	.042	1.07	6.615	168.02
CC-175-PC	.970	24.64	.760	19.30	.640	16.25	1.000	25.40	.043	1.09	.048	1.21	6.615	168.02
CC-200-PC	1.270	32.25	.910	23.11	.785	19.93	1.150	29.21	.043	1.09	.048	1.21	7.315	185.80
CC-250-PC	1.270	32.25	.910	23.11	.785	19.93	1.150	29.21	.043	1.09	.048	1.21	5.440	138.17
CC-202-PC	1.390	35.30	1.010	25.65	.885	22.47	1.150	29.21	.055	1.39	.064	1.62	7.315	185.80
CC-252-PC	1.390	35.30	1.010	25.65	.885	22.47	1.150	29.21	.055	1.39	.064	1.62	5.440	138.17
CC-302-PC	1.740	44.19	1.270	32.25	1.105	28.06	1.400	35.56	.068	1.72	.083	2.10	7.315	185.80
CC-352-PC	1.740	44.19	1.270	32.25	1.105	28.06	1.400	35.56	.068	1.72	.083	2.10	6.065	154.05
CC-402-PC	2.182	55.42	1.593	40.46	1.388	35.25	1.700	43.18	.090	2.28	.103	2.61	7.815	198.50
CC-502-PC	2.800	71.12	2.060	52.32	1.750	44.45	1.900	48.26	.115	2.92	.125	3.17	9.625	244.47
CC-602-PC	3.535	89.78	2.610	66.29	2.175	55.24	2.400	60.96	.140	3.55	.148	3.75	11.250	285.75
CC-652-PC	3.800	96.52	2.890	73.41	2.450	62.23	2.400	60.96	.150	3.81	.160	4.06	11.250	285.75
CC-702-PC	4.225	107.31	3.350	85.09	2.790	70.86	2.400	60.96	.165	4.19	.170	4.32	11.250	285.75

## COLLAPSIBLE CORES

### RT SERIES GRINDING RINGS

Grinding Rings for Collapsible Cores securely hold the core segments in place against the center pin when grinding, high speed machining or EDM'ing details.



RT CORE GRINDING RINGS	
CATALOG NUMBER	CORE SIZE (PREFIX CC)
RTGR125	125
RTGR150	150/175
RTGR200	175/200/202/250/252
RTGR300	302/352
RTGR400	402
RTGR500	502
RTGR600	602
RTGR650	652
RTGR700	702

# COLLAPSIBLE CORES

## RT & MINICORE® SERIES CONSTRUCTION

### Description of Components and Basic Operation

Both styles of the Collapsible Cores (Standard and MiniCores®) are three-part assemblies, designed for simplicity of installation, reliability in operation, and long life. The three parts include a Collapsible Core, a Positive Collapse Sleeve, and a Center Pin.

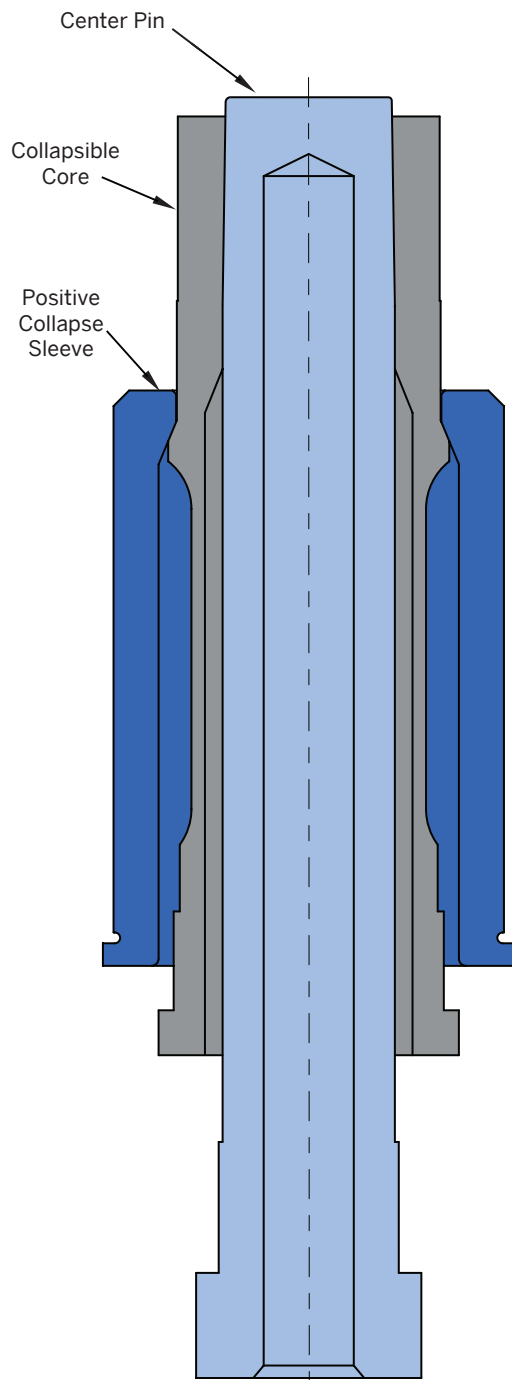

#### Collapsible Core

**M** A-2 **H** 54-57 HRC

- Designed to collapse independently when the center pin is withdrawn.
- The fit between segments is controlled to permit flash-free molding.

#### Positive Collapse Sleeve

**M** 52100 **H** 54-57 HRC

- Designed to function if the Collapsible Core should fail to collapse independently. In normal operation, the PC Sleeve is not functioning. It is essential to have such a unit for maximum safety and reliability in automatic and semi-automatic operation.

#### Center Pin

**M** D-2 **H** 60-62 HRC

- Serves to expand the segments of the Collapsible Core to their molding position.
- The pin must protrude beyond the face of the collapsing core segments, and it must have a radius around its top edge to operate properly.

#### Application Guidelines

- Standard Collapsible Cores have a Max. OD ("A") of thread or configuration ranging from .720" (18.29mm) - 4.225" (107.31mm) and offer complete 360° thread or undercut geometry.
- MiniCores have a Max. OD of thread or configuration ranging from .645" (16.38mm) - .965" (24.51mm) and offer up to 70% full thread or undercut geometry. (Internal geometry is interrupted in three places to allow core segments to collapse.)
- Molded parts do not need to be closed at one end. They can be partially or completely open. Also, undercuts do not need to be continuous.
- Cores are capable of operating without benefit of lubrication, however, treating the Collapsible Core with an additional treatment for wear reduction or corrosion resistance is beneficial.
- Custom cores with size requirements that fall outside of the standard Collapsible Core and MiniCore ranges are available. In addition, finished cores with machined, EDM'd, or ground details can be supplied. Contact Roehr Tool at [information@roehrtool.com](mailto:information@roehrtool.com) for an application review and quotation.

# MINICORES

## MINICORE® SERIES

Roehr's MiniCores broaden the applications of collapsible core molds to parts as small as 0.425 inches. Due to the smaller diameters involved, these MiniCores employ three larger collapsing segments combined with three narrow, non-collapsing blades which are part of the center pin. As a result, the internal undercut geometry is not 360 degrees around but instead interrupted in three places. The 3-blade design allows for more collapse which means a deeper undercut feature can be released.

In addition to threads, other configurations such as dimples, cut-outs or protrusions beyond the capabilities of unscrewing molds can be successfully molded. Three standard sizes of MiniCores are available with diameters from 0.425 to 0.965 inches.

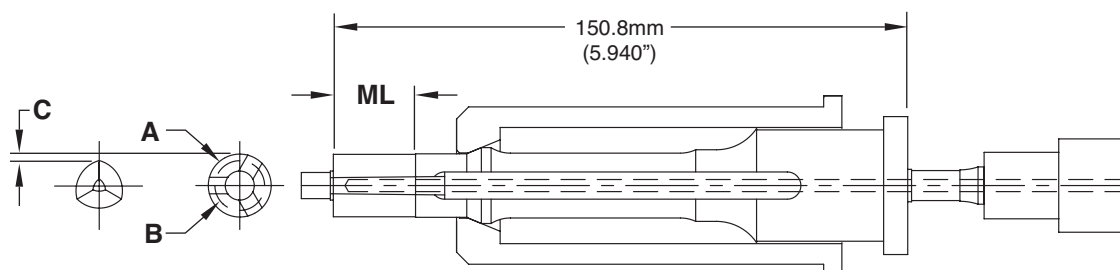

CATALOG NUMBER	For Closure Diameter Range	A Maximum Outer Diameter		B Minimum Inner Diameter		Center Pin Dia. (At top of Collapsible Core)		Width of (3) Non-Collapsing Center Pin Blades (At Top of Core)		ML Max. Molded Length (Including Mold Shut-Off)		C Collapse per Side at Top of Core	
		mm	Inch	mm	Inch	mm	Inch	mm	Inch	mm	Inch	mm	Inch
CCM-0001	13-16	.645	16.38	.425	10.80	.300	7.62	.170	4.32	.850	21.59	.052	1.32
CCM-0002	17-20	.805	20.45	.560	14.22	.420	10.67	.190	4.83	.850	21.59	.057	1.45
CCM-0003	21-24	.965	24.51	.710	18.03	.560	14.22	.200	5.08	1.000	25.40	.059	1.50



# EXPANDABLE CAVITIES

## EX-CAV<sup>®</sup> SYSTEM

Expandable Cavities (Ex-Cavs) mold undercuts such as threads, dimples, and protrusions.

The patented Ex-Cav design eliminates the engineering, maintenance, and machining required for side action mechanisms which results in smaller molds or higher mold cavitation.

### Technical Information:

- Four sizes offered to satisfy a wide range of parts.
- The Ex-Cav expands along a conical shape, 10° per side.
- Manufactured from A-2, 54-57 HRC material for repeatable expansion. For optimal performance, the Ex-Cavs should ride against a hardened striker insert which can be manufactured by Roehr or customer supplied.
- Maximum temperature: 260°C / 500° F
- Expandable Cavities generally operate without lubrication.
- Ex-Cavs can be ordered with molding detail for a 'mold ready' component.
- Ex-Cav Fixtures for machining details in house are also available.
- Custom Ex-Cavs are available. Also, when an entire part is formed within the cavity, an A-Series Ex-Cav can be provided.

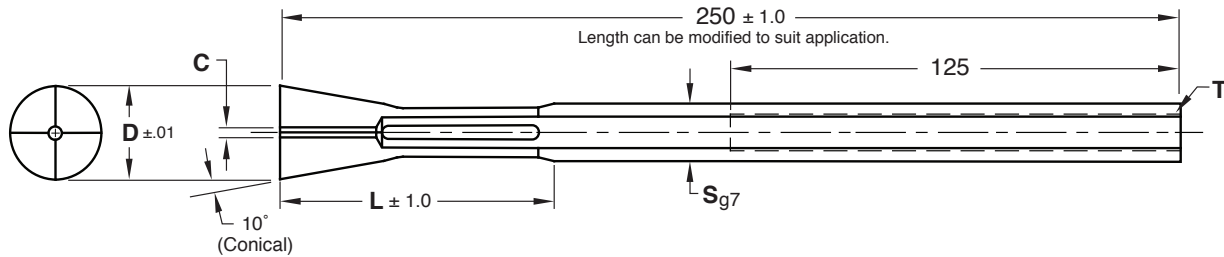
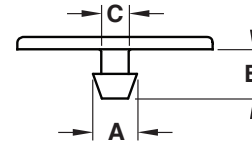
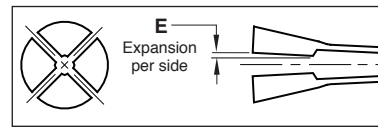

**M** A-2    **H** 54-57 HRC

CATALOG NUMBER	D Ex-Cav Diameter	A Maximum Part Diameter -10° per side	B Maximum Molding Length	C Minimum Part Inner Diameter	E Expansion Per Side	F Min. Wall Thickness	L Expansion Length	S Body Diameter	T Thread	X Minimum Ejection Stroke (Prev. page)
<b>EXCAV20</b>	20mm .787in	14mm .551in	13mm .512in	2.5mm .098in	1.6mm .063in	3mm .118in	59mm 2.323in	14mm .551in	M8	15mm .591in
<b>EXCAV26</b>	26mm 1.024in	18mm .709in	20mm .787in	3.5mm .138in	2.5mm .098in	4mm .157in	76mm 2.992in	16mm .630in	M10	15mm .591in
<b>EXCAV38</b>	38mm 1.496in	30mm 1.181in	27mm 1.063in	4mm .157in	3mm .118in	4mm .157in	89mm 3.504in	27mm 1.063in	M18	20mm .787in
<b>EXCAV50</b>	50mm 1.969in	40mm 1.575in	39mm 1.535in	5.5mm .217in	3.5mm .138in	5mm .197in	101mm 3.976in	34mm 1.339in	M24	20mm .787in

Custom Ex-Cavs are available for molded parts up to and beyond 500mm.  
Ex-Cav sizes outside of this chart are available as customs.

## MOUNTING KITS &amp; MACHINING SPECS

## Hollow Bolt Mounting Kit Includes:

- Key (7 Thk. x 8 x 40)
- Hollowed Bolt
- Standard DIN H-13 Ejector Pin (400mm Long)
- Spacer

## Pin Bolt Mounting Kit Includes:

- Key (7 Thk. x 8 x 40)
- Threaded Bolt/Pin (H-13, 40-44 HRC, 280mm Long)
- Spacer

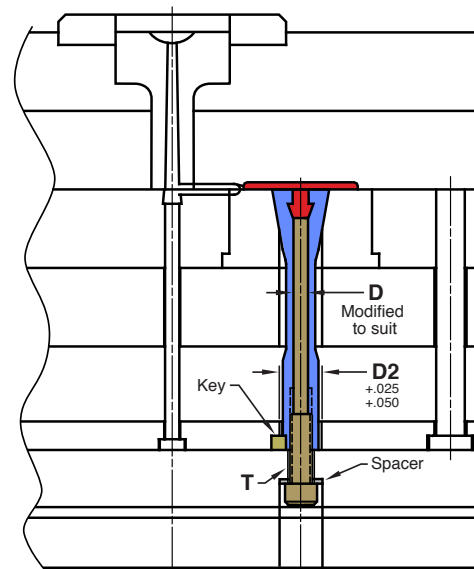
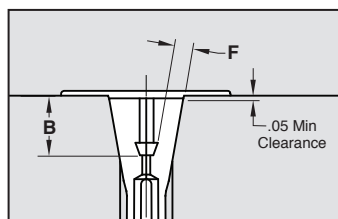
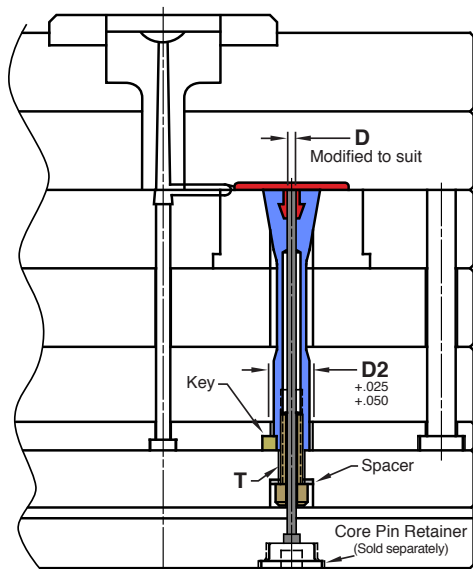

EX-CAV NUMBER	D Nominal Pin Diameter	T Bolt Size	Spacer Size (ODxThk)	D2	HOLLOW BOLT KIT NUMBER
EXCAV20	3.5mm .138in	M8-1.25 x 40	22x4mm .866x.157in	14mm .551in	<b>EXC20BH</b>
EXCAV26	4mm .157in	M10-1.5 x 40	23x4mm .906x.157in	16mm .630in	<b>EXC26BH</b>
EXCAV38	10mm .394in	M18-2.5 x 50	33x6mm 1.299x.236in	27mm 1.063in	<b>EXC38BH</b>
EXCAV50	14mm .551in	M24-3 x 55	42x6mm 1.654x.236in	34mm 1.339in	<b>EXC50BH</b>

EX-CAV NUMBER	D Pin Diam. ± .05	T Bolt Thread	Spacer Size (ODxThk)	D2	PIN BOLT KIT NUMBER
EXCAV20	6.0mm .236in	M8-1.25	22x4mm .866x.157in	14mm .551in	<b>EXC20BP</b>
EXCAV26	7.7mm .303in	M10-1.5	23x4mm .906x.157in	16mm .630in	<b>EXC26BP</b>
EXCAV38	14.5mm .571in	M18-2.5	33x6mm 1.299x.236in	27mm 1.063in	<b>EXC38BP</b>
EXCAV50	19.8mm .780in	M24-3	42x6mm 1.654x.236in	34mm 1.339in	<b>EXC50BP</b>

US PATENT NUMBER: 8,038,433

## EX-CAV MACHINING FIXTURES

Machining Fixtures for ExCavs securely hold the expanding segments in place when grinding, high speed machining or EDM'ing details.

CATALOG NUMBER	EXCAV SIZE	"A"	"B"	"C"	"D"	Locking Screws
EXCMF20	EXCAV20	41.28mm 1.625in	76.20mm 3.000in	14.03mm .552in	12.70mm .500in	10-32 x .50"
EXCMF26	EXCAV26	44.25mm 1.750in	101.60mm 4.000in	16.03mm .631in	12.70mm .500in	10-32 x .50"
EXCMF38	EXCAV38	53.98mm 2.125in	127.00mm 5.000in	27.03mm 1.064in	12.70mm .500in	10-32 x .50"
EXCMF50	EXCAV50	66.68mm 2.625in	152.40mm 6.000in	34.03mm 1.340in	12.70mm .500in	10-32 x .50"

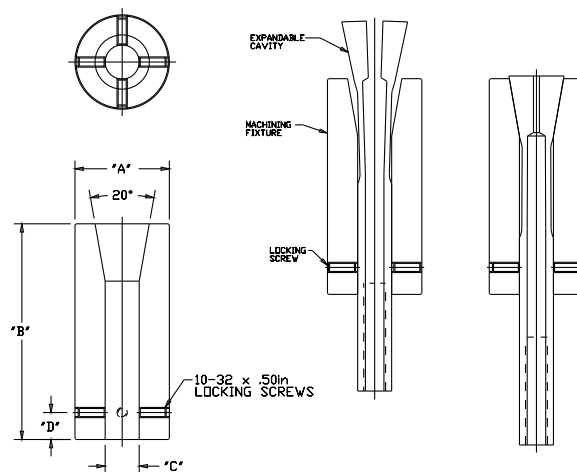

PULL EXPANDABLE CAVITY DOWN INTO FIXTURE AND TIGHTEN LOCKING SCREWS.

Roehr can also supply Ex-Cavs with fully machined molding details upon request.

# EXPANDABLE CAVITIES

## EX-CAV<sup>®</sup> SEQUENCE

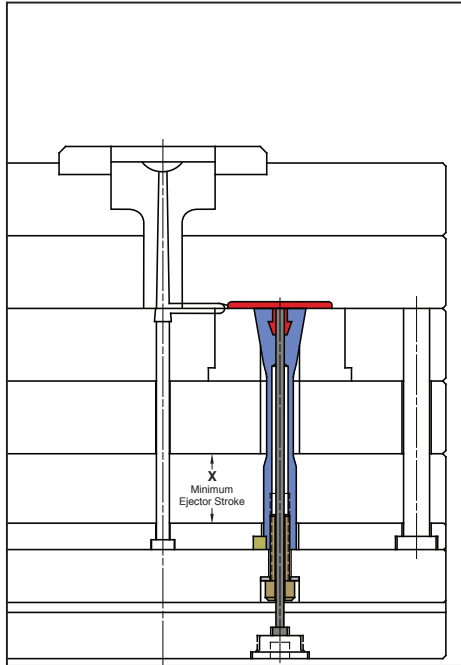

**Mold Closed-B Series**

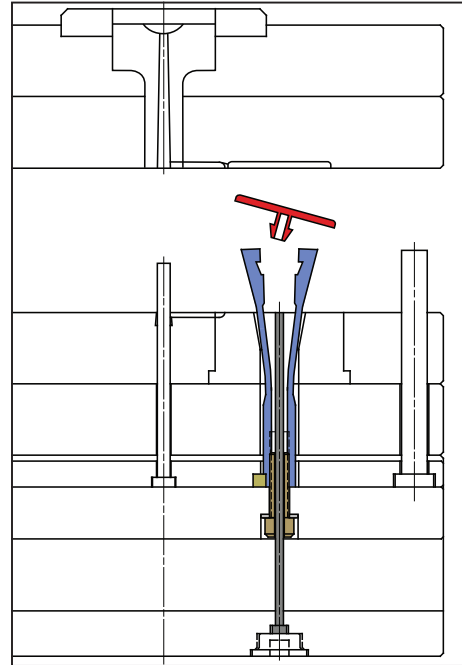

**Mold Open-B Series**

B-Side Expandable Cavities are anchored into the ejector plates and actuated during the machine knock-out sequence. Often times a 2nd ejector plate set is used for final part ejection with an ejector pin or sleeve. Runners may go across the top of the EXCAV and the molded parts edge gated as long as this does not interfere with the EXCAV expansion.

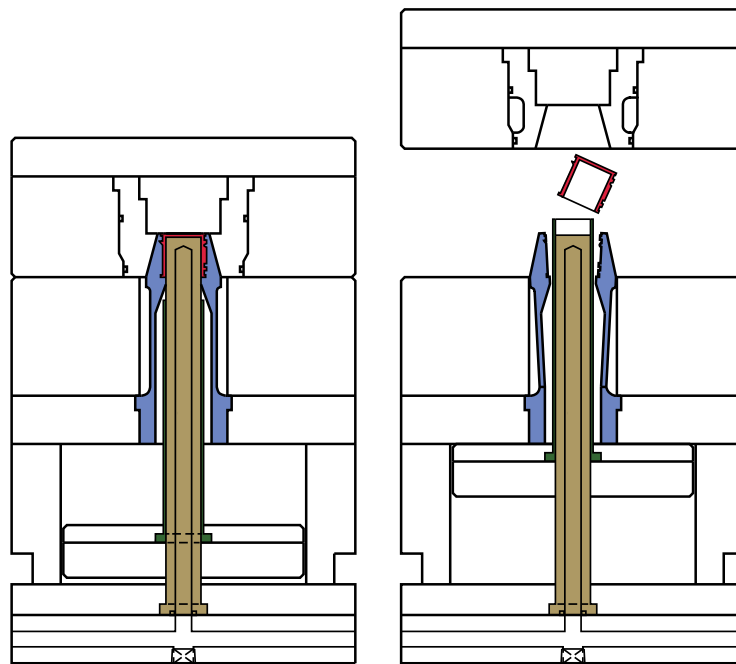

**Mold Closed-A Series**

**Mold Open-A Series**

A-Side Expandable Cavities are anchored between the mold "B" plate and support plate and actuated immediately during mold open/close at the main parting line by the cavity insert. The molded parts are then generally ejected with an ejector pin or sleeve. Because there is airspace around the A-Side EXCAV at the parting line, the molded parts must be top gated with a 3-plate cold runner or hot tip.

# EXPANDABLE CAVITIES

EX-CAV<sup>®</sup> CUSTOMS



## ENGINEERING SERVICES

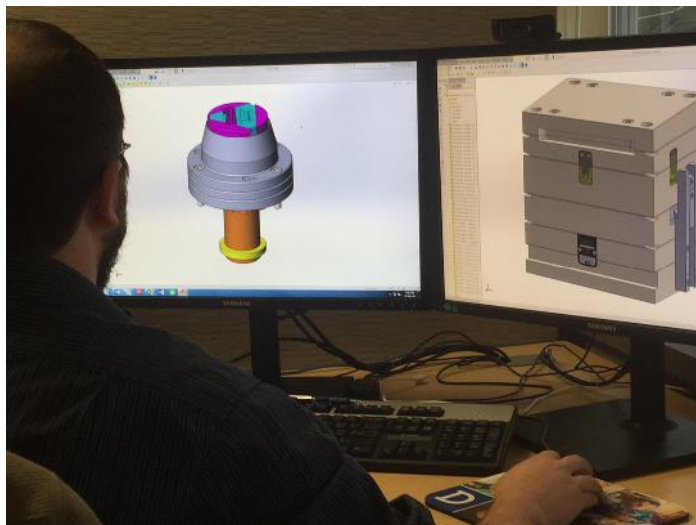
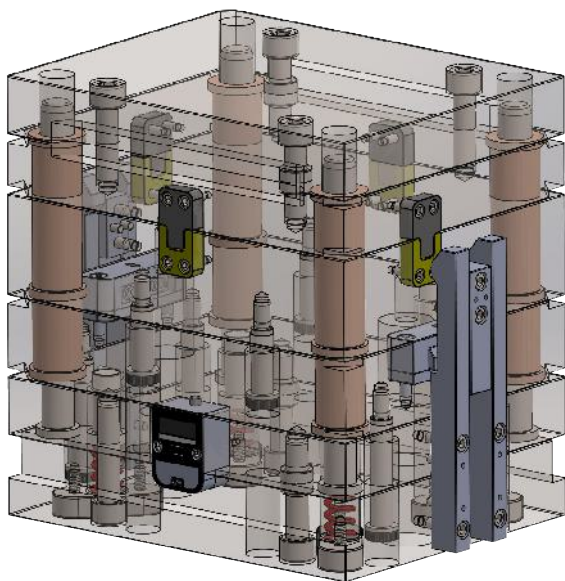

All standard Roehr Tool products are supported with 3d models, pre-engineered moldbase specifications and technical data pages. These can be found on our web-site or by calling Roehr Tool directly.

For custom engineered and manufactured product, Roehr Tool will provide all moldbase and installation information required as it relates to our product. This includes 2d and 3d product CAD data, mold base plate thicknesses, sequencing requirements, bore and pocket details etc.

Our goal is to avoid your mold designers wasting time wondering how something is going to fit, function or install into your mold.

### Some additional services offered by the Roehr Tool Engineering Team are:

- Molded Product Design Reviews.
- Mold Design Reviews.
- Molded Product Design. (DFM)
- Complete or Partial Mold Designs.
- Virtual and On-Site Maintenance Training.
- Mold Retrofit Designs. (Unscrewing to Collapsible Core)

**To whatever extent your engineering requirements are from simple molded part change recommendations to complete mold designs, the Roehr Tool Engineering Team is here to support you all the way, resulting in a successful and profitable experience for you and your customers.**

## PROTOTYPING AND PRODUCT DEVELOPMENT

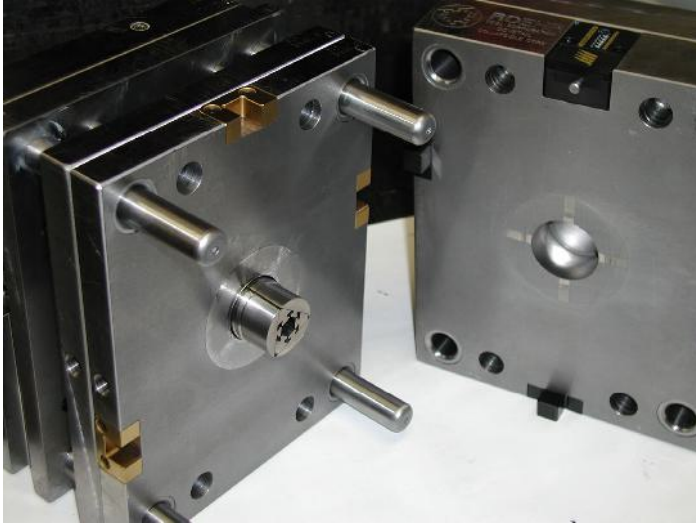

Roehr Tool Solutions owns many different mold bases that accept our Collapsible Cores and Expandable Cavities.

These bases are available for customer use for prototyping or product development generally at a very low or no cost at all depending on project scope. The availability of these bases has allowed some customers to save considerable time and money during the product development period of their programs.

To see if Roehr Tool has a mold base fit for your product development or prototype, contact Roehr Engineering at [information@roehrtool.com](mailto:information@roehrtool.com)

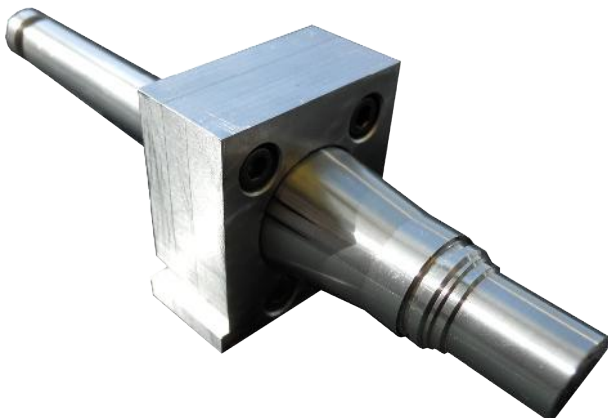
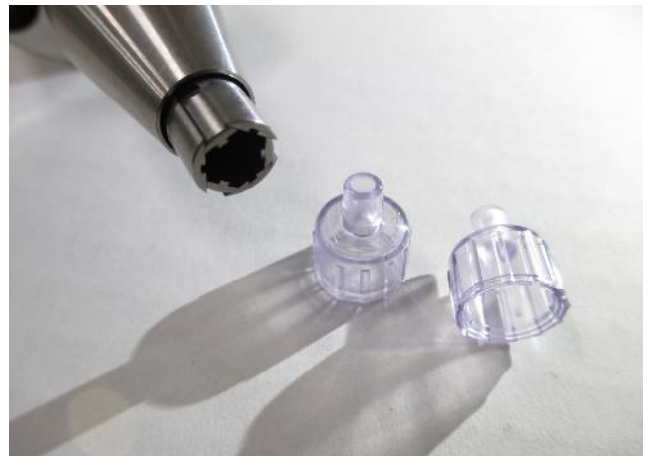
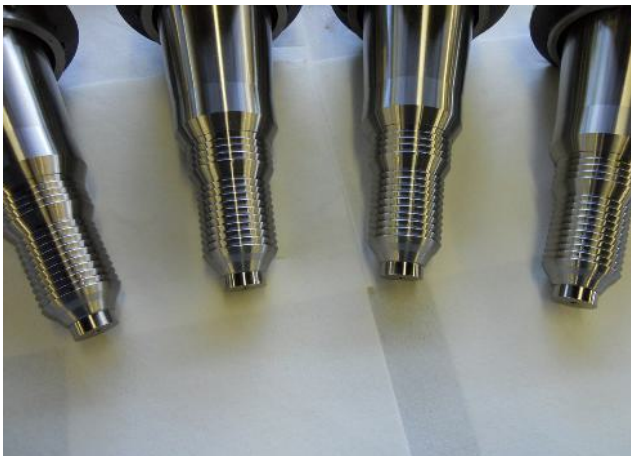

# Companion Products from **PROGRESSIVE** C O M P O N E N T S

Roehr Tool products are built for long mold life at high productivity. To ensure optimum performance, Roehr recommends the following products from Progressive Components for proper mold alignment, sequence and maintenance.

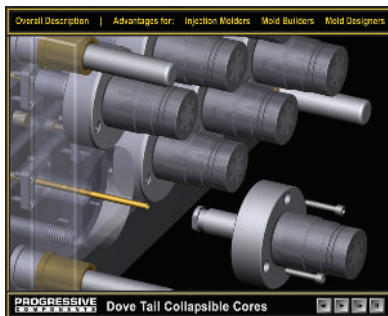

For more information, visit [www.procomps.com/Demo](http://www.procomps.com/Demo) or contact [tech@procomps.com](mailto:tech@procomps.com)

# Companion Products from **PROGRESSIVE COMPONENTS**

## Z-Series Alignment Locks

Protecting the mold parting line is crucial to keeping the mold running smooth, consistent and in good alignment, as well as to prevent premature wear between the moving components. Progressive's Z-Series Alignment Locks have been engineered to do just that, and have been tested and proven to outperform other locks on the market. This level of performance is achieved through a combination of engagement geometry and particulate capturing, as well as materials and treatments, and now comes complete with a lifetime guarantee. With Progressive's Z-Series Locks, part quality can be assured while gaining cost savings through mold efficiency and less maintenance.

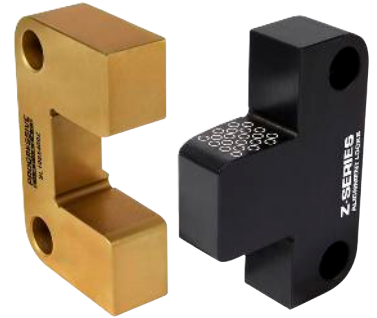

## Z-Series Bar Locks

Most Collapsible Core molds sequence as two stage ejection which means extending large plates of steel away from the platens, leaving them with less support. One solution to keep a Collapsible Core mold in alignment is to utilize bar locks that extend across the mold providing support to mold sections when extended away from the platen. The bars are mounted along the side of the mold, guided by wear plates in each plate section. They also assist in taking the weight off of the leader pins to precisely align plates to shutoffs or to align the two halves of large molds.

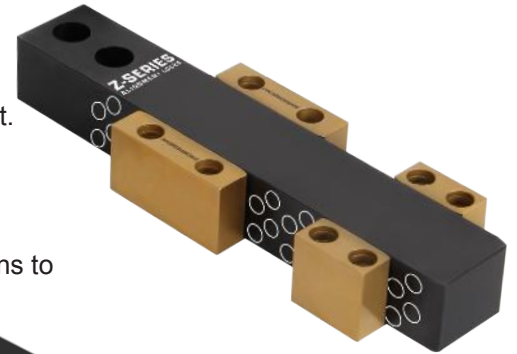

## External Plate Locks

The simplest method for consistent plate staging with Collapsible Core molds is to use the press KO to drive plates and use a secondary latch to control the plate movement.

Progressive Components' External Plate Locks are a mechanical latch component that mounts to the outside of the mold and works off of the press knock outs, enabling easier set-up, and more reliable plate sequencing.

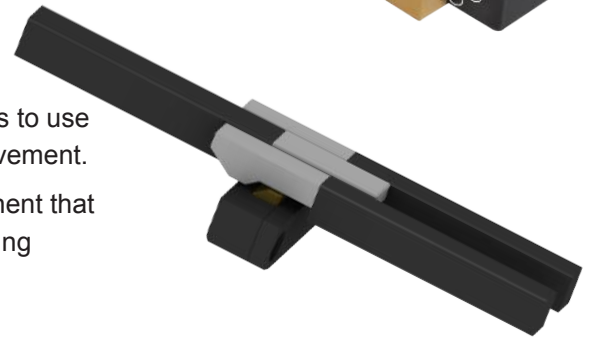

## CVe® Monitor

Roehr Tool product molds achieve their best performance when run with a consistent process, while adhering to defined maintenance standards, thereby preventing premature wear or failure.

To assist, Progressive's CVe Monitor is recommended on each tool, to monitor and track cycle time and mold efficiency. The CVe Monitor comes with free software so you can plug in your mold and download data on mold performance versus a predetermined standard. There is also an option to track and document mold maintenance intervals, and more.



## Frequently Asked Questions (FAQ's)

### Where are Roehr products manufactured?

All of Roehr products are designed manufactured in the USA with our home base location just out side of Boston Massachusetts.

### What are Roehr products made from?

Typically a combination of A2 and D2 Tool steels. A2 is used mainly for the flexing steel products for its combination of hardness, toughness and flexing properties. D2 is generally used for center pins and DT Core Carrier Assemblies. The combination of A2 and D2 together exhibit phenomenal wear resistant and long life expectancy together.

### Are coatings recommended for Roehr products?

Coatings are available and great for wear resistance, corrosion resistance and overall ease of cleaning Roehr components, but are generally not necessary unless running a material such as PVC.

All of Roehr products are made from the highest quality tool steels and hardened between 54rc and 62rc depending on the component providing a long life in an uncoated form.

### How big and how small can the molded parts be when using Roehr products?

For collapsible cores, the size range is typically from 7mm to 400mm although we can design and manufacture both smaller and larger sizes in some instances. For Expandable Cavities, the size range is unlimited.

### How many cycles can we expect out of a Roehr product?

With proper care and maintenance, Roehr products are engineered to last the life of the mold. Our flexing steel products are engineered with infinite spring life and will not fatigue. Our mechanical products are engineered for minimal wear contact areas and there are tools in the industry with well over 5 million cycles on them.

### Do you guarantee the number of cycles the tools will provide?

Because we do not have control over the environment in which our tools are used, it is impossible for us to guarantee a number of cycles. We do guarantee that our products are manufactured with the highest quality and are dimensionally within publicized or agreed upon specifications. Proper care and maintenance is critical to the life of our products as with any mechanical action in an injection mold.

### What is maintenance like with Roehr products?

For Expandable Cavities, maintenance is very simple as they are constructed out of one piece of steel. When out of the mold the ExCavs are in the expanded position and easily cleaned including in-between the segments using traditional methods. For Collapsible Cores, the units should be disassembled and then cleaned with traditional methods. The use of an ultrasonic bath makes maintenance even easier but with ALL Roehr products, care should be taken when handling the many exposed sharp edges when out of the mold.

### Does Roehr provide maintenance training?

Yes, the Roehr team can provide maintenance training in many ways including presentations, webinars and even on-site depending on the project. We realize that for a customer to have a most pleasant experience with our products, they must be properly trained and educated on not only the function but care and maintenance of the product.

### We have never used Roehr products before. what can we expect in terms of technical support?

Roehr's engineering team will provide you with as much or as little technical assistance as you require. From simple question answering to mold base pocket and bore information, all the way to complete mold designs are available from the team. We recommend that you get the Roehr Engineering Team involved early on in the product or mold design phases of your project.

### How do I know if my molded part will work with a Roehr Tool product?

The easiest way to see if you have a fit for Roehr products is to send you a part drawing or model to Roehr for a review. We have Application Engineers on staff who review part geometry every day. We often tell customers not to spend too much time searching through catalog data as we can turn around a review and recommendation very quickly.

### How do I contact Roehr Tool Solutions, Inc.?

Contact us at [information@roehrtool.com](mailto:information@roehrtool.com), visit our web-site at [www.roehrtool.com](http://www.roehrtool.com) or call 1-978-562-4488

# NOTES

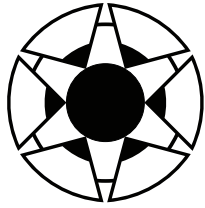

**ROEHR**  
TOOL SOLUTIONS, INC.



**No Racks, No Gears, Just Profits!**

52 Old Willard Rd. Leominster, MA 01453 Ph: 978-562-4488  
information@roehrtool.com  
www.roehrtool.com

