



STACKIT®
STACK MOLD SYSTEM

Center Positioning
 Gear Housing Assembly maintains the position of the center section and protects gears and bearings from the molding elements.

Rack Spacers
 Used for securing the gear racks to the movable halves.

Tie Bar Pads
 Standard Tie Bar Pads are available with or without a machined radius or lubrication passages.

Ejection Actuation
 Standard cylinders for actuating ejector plates, with standard couplings to eliminate any threading into plates.

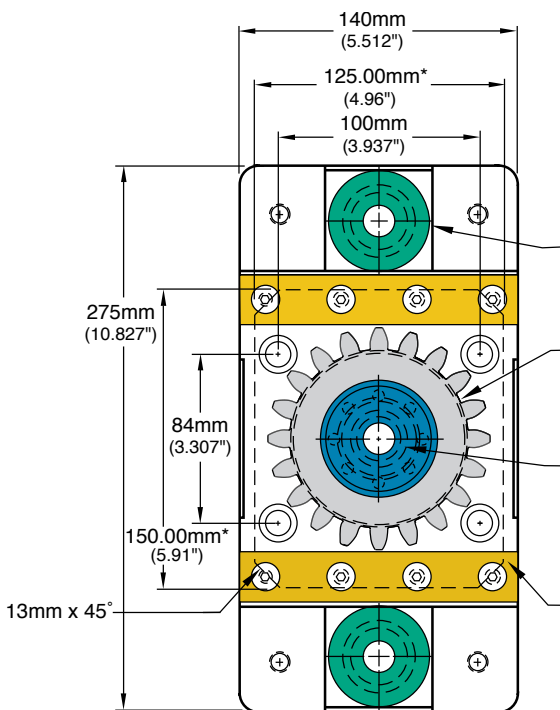
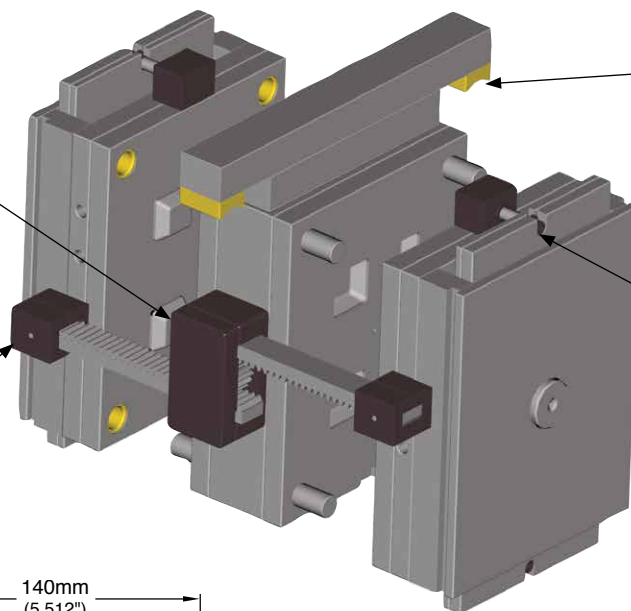

*Mounting Pocket Dimensions +.05 / -.00

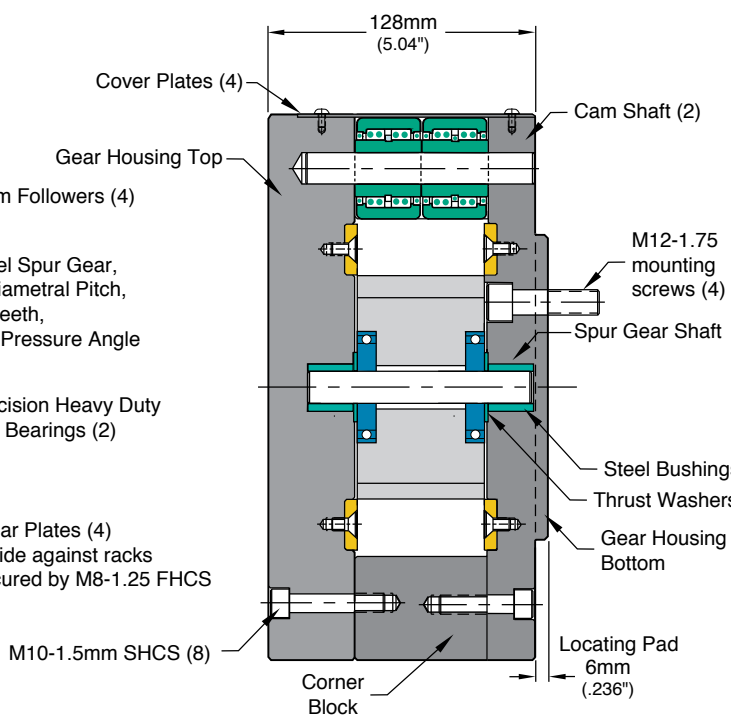

APPLICATION GUIDELINES

- Max center section effective weight per StackKit pair is 4,536kg (10,000lbs)
- Ensure mold is within maximum projected weight of molding machine.
- When mounting racks to a mold, ensure both sides are timed equally.
- Install two gear housings in center, as shown above. For large molds, four housings should be installed, two per side.

CATALOG NUMBER	DESCRIPTION
SK-GHA-250	Gear Housing Assembly
SK-SPGRKIT	Spur Gear Replacement Kit

The Spur Gear Replacement Kit contains (1) Spur Gear, (1) Cam Shaft, (2) Ball Bearings, (2) Thrust Washers, and (2) Steel Bushings.

STACKIT® RACK SPACERS

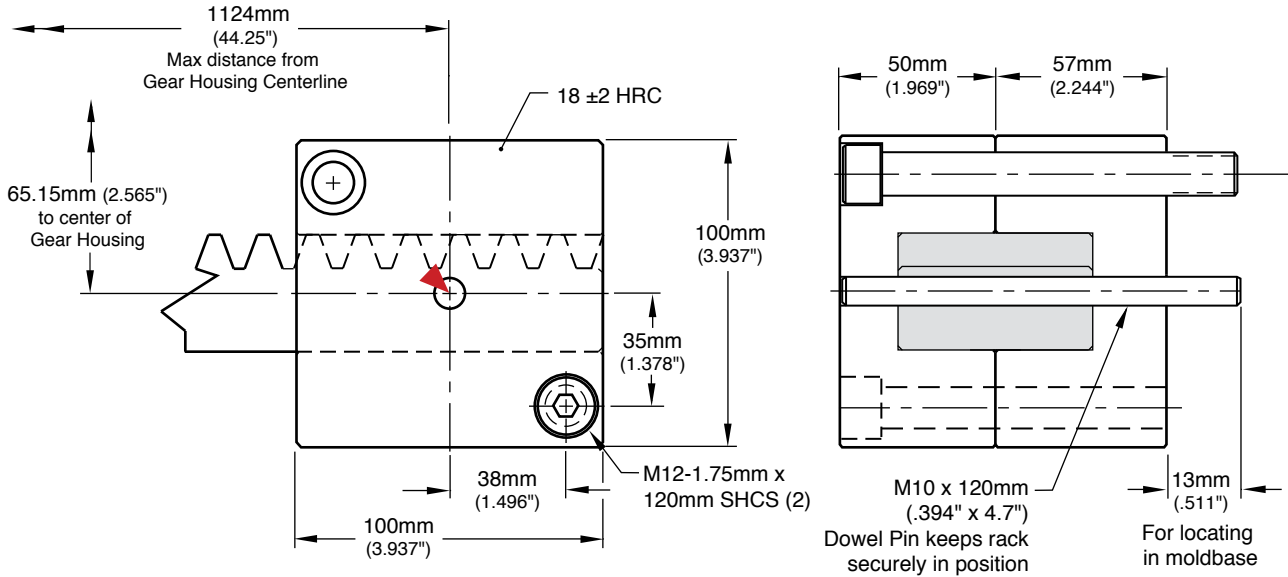

M A-36 **H** Pre-Hard **S** Black Oxide

▶ CAD insertion point

CATALOG NUMBER	DESCRIPTION
SK-RSA-250	Rack Spacer Assembly

Screws and locating dowel included.

STACKIT® RACKS

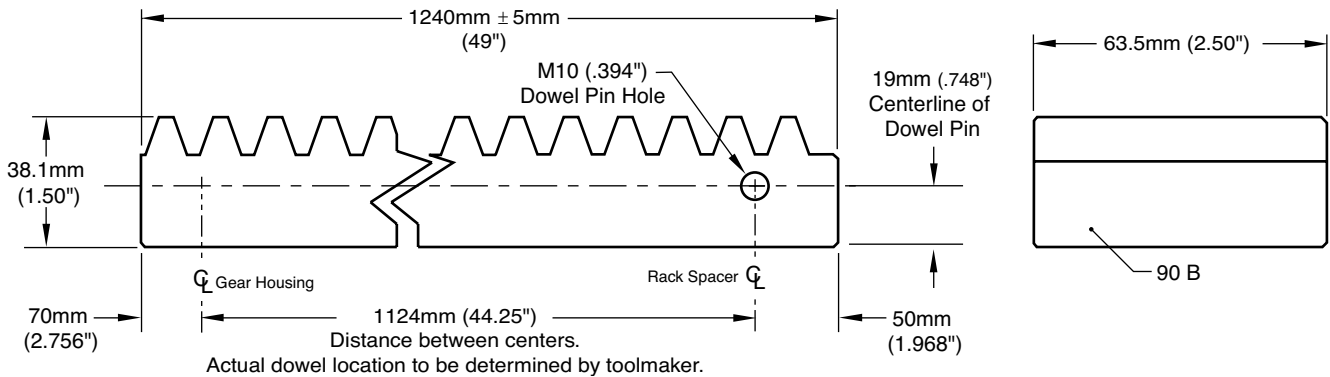

M CRS

CATALOG NUMBER	DESCRIPTION
SK-RC-250	Rack (Sold Individually)



STACKIT® TIE BAR PADS



SK-TBP-35
Tie Bar Pad Blanks

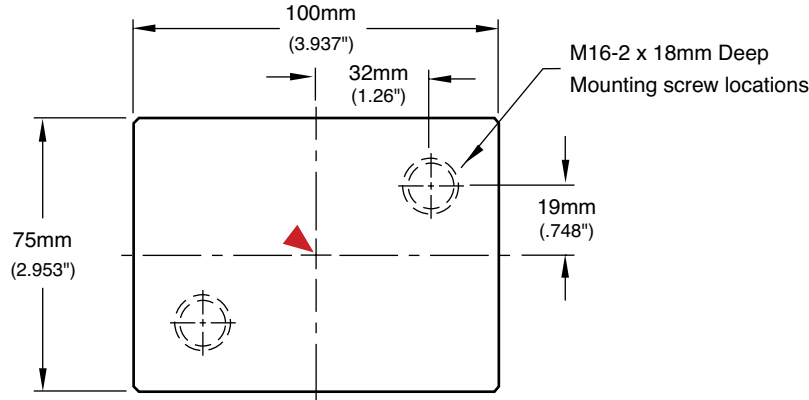

SK-TBP-R
Tie Bar Pad with finished radius. Please specify “-R” when ordering.

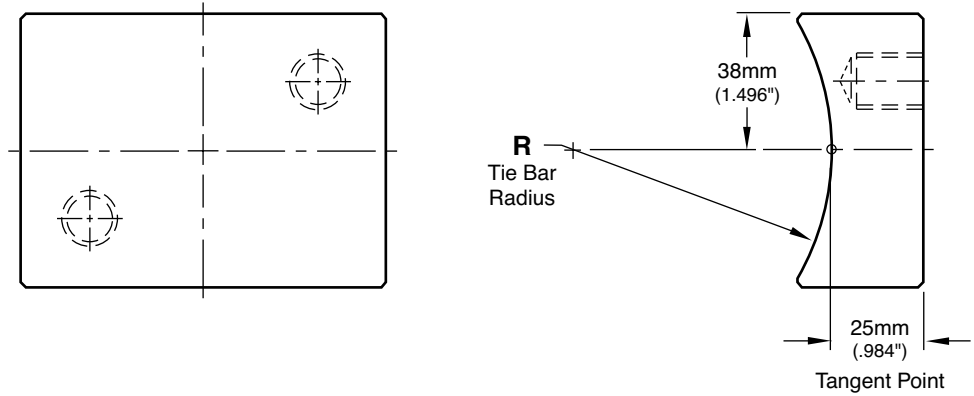

SK-TBP-RG
Tie Bar Pad with finished radius, grease grooves, and zerk fitting. Please specify “-RG” when ordering.

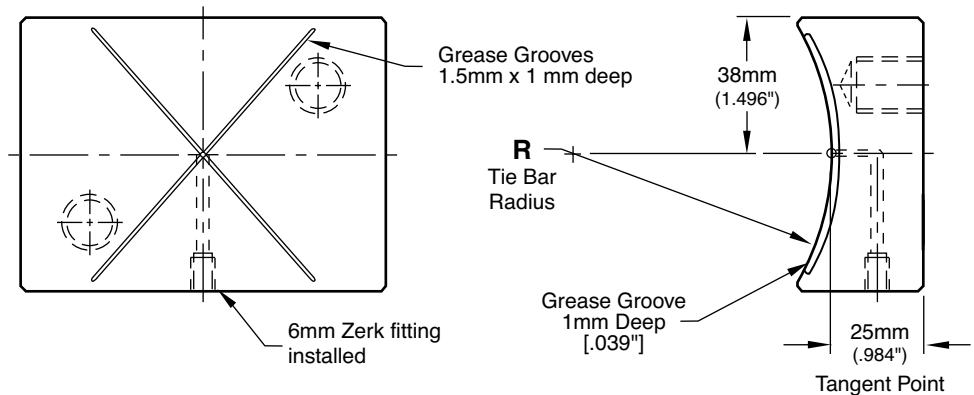

M CA954 Solid Bronze

CAD insertion point

CATALOG NUMBER	DESCRIPTION
SK-TBP-35	Tie Bar Pad Blanks (No Radius)
SK-TBP-R	Tie Bar Pads with machined radius
SK-TBP-RG	Tie Bar Pads with machined radius, grease grooves and zerk fitting

Sold individually.

STACKIT® EJECTION ACTUATION

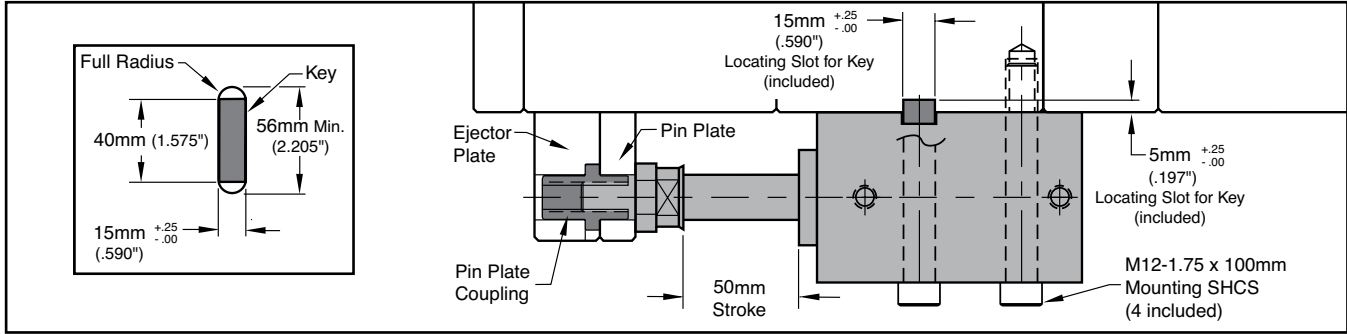

CYLINDERS

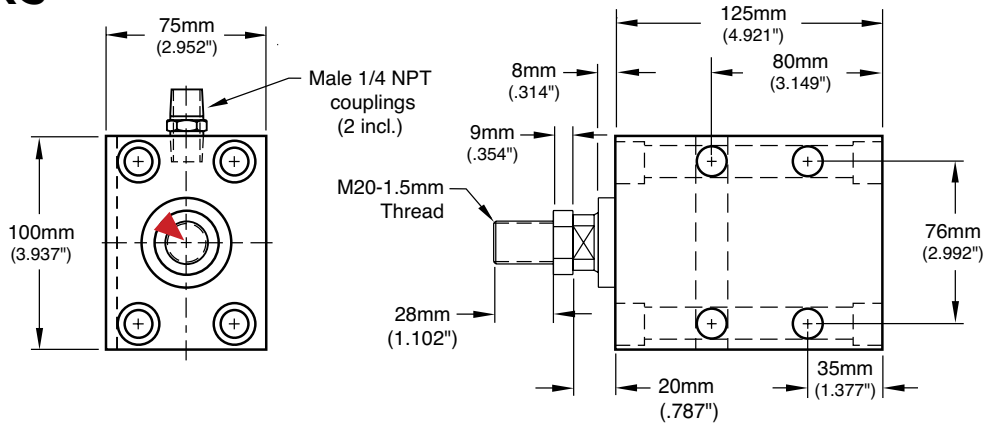

APPLICATION GUIDELINES

- 50mm (2") Stroke
- Rated up to 3200 psi
- Temperature: 220 °F (100 °C) max
- Includes (2) NPT couplings and Locating Key

▶ CAD insertion point

CATALOG NUMBER	DESCRIPTION
SK-CYL-50	50mm Block Cylinder

PIN PLATE COUPLINGS

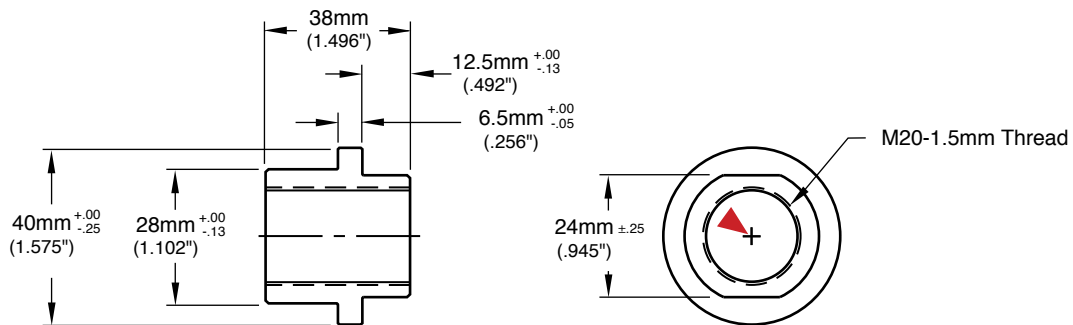

M AISI 4140 **S** Black Oxide ▶ CAD insertion point

CATALOG NUMBER	DESCRIPTION
SK-PPC-20	M20-1.55mm Pin Plate Coupling